

**UNITED STATES PATENT AND TRADEMARK OFFICE**

---

**BEFORE THE PATENT TRIAL AND APPEAL BOARD**

---

Merck Sharp & Dohme LLC,  
Petitioner,

v.

Halozyme Inc.,  
Patent Owner.

---

Case No. PGR2025-00033  
U.S. Patent No. 12,049,652

---

**PETITION FOR POST GRANT REVIEW**

## TABLE OF CONTENTS

<b>I.</b>	<b>Introduction.....</b>	<b>1</b>
<b>II.</b>	<b>Compliance with PGR Requirements.....</b>	<b>4</b>
	<b>A. Certification of Standing .....</b>	<b>4</b>
	<b>B. Mandatory Notices .....</b>	<b>6</b>
	1. <i>Real Party-in-Interest .....</i>	<i>6</i>
	2. <i>Related Proceedings .....</i>	<i>6</i>
	3. <i>Counsel and Service Information.....</i>	<i>6</i>
<b>III.</b>	<b>Grounds .....</b>	<b>6</b>
<b>IV.</b>	<b>Background on the '652 Patent .....</b>	<b>8</b>
	<b>A. Field of the Patent.....</b>	<b>8</b>
	1. <i>Protein Structures .....</i>	<i>8</i>
	2. <i>Hyaluronidase Enzymes.....</i>	<i>11</i>
	3. <i>Protein Engineering.....</i>	<i>13</i>
	<b>B. Person of Ordinary Skill in the Art.....</b>	<b>15</b>
	<b>C. Prosecution History.....</b>	<b>16</b>
	<b>D. The Challenged Claims.....</b>	<b>16</b>
	1. <i>The Claims Encompass a Staggering Number of Modified         PH20 Polypeptides.....</i>	<i>17</i>
	2. <i>The Claims Encompass Particular Mutants: D320K or D320S         PH20<sub>1-447</sub> .....</i>	<i>20</i>
	3. <i>The Claims Are Restricted to One of Two Alternative         Embodiments in the Patents: “Active Mutants” .....</i>	<i>21</i>
<b>V.</b>	<b>All Challenged Claims Are Unpatentable Under § 112 and None Are Entitled to Benefit to Any Pre-March 13, 2013 Application .....</b>	<b>25</b>
	<b>A. All Claims Lack Written Description.....</b>	<b>26</b>
	1. <i>Claims 1-2, 6-15, and 24-25 Lack Written Description .....</i>	<i>31</i>

- a) The Claims Capture Massive and Diverse Genera of Enzymatically Active PH20 Polypeptides.....31
- b) The Claims Capture Modified PH20 Polypeptides the Common Disclosure Says to Avoid or Not Make .....32
  - (i) Multiply-Modified PH20 Mutants to Not Make ..33
  - (ii) Substitutions to Avoid in Active Mutants .....34
  - (iii) PH20 with Significant C-terminal Truncations Can Lose Activity .....35
- c) Empirical Test Results of Single-Replacement Modified PH20 Polypeptides Do Not Identify Multiply-Modified Enzymatically Active PH20 Polypeptides.....39
  - (i) The Data Concerning Single-Replacements Is Not Probative of Multiple-Replacement Mutants .....39
  - (ii) Purported Stability Data Is Not Reliable or Probative.....43
- d) The Common Disclosure’s Research Plan Does Not Identify Multiply-Mutated Enzymatically Active PH20 Polypeptides.....46
- e) The Common Disclosure Does Not Identify a Structure-Function Relationship for Multiply-Modified, Enzymatically Active PH20 Polypeptides.....50
- f) The Common Disclosure Does Not Describe a Representative Number of Multiply-Modified Enzymatically Active PH20 Polypeptides.....53
- g) The Claims Capture Multiply-Modified PH20 Polypeptides the Disclosure Excludes from the Class of Enzymatically Active PH20 Proteins .....58
- 2. *Dependent Claims 3-5, 16-23, and 26-40 Lack Written Description*.....59
  - a) Claims 3-4.....59
  - b) Claims 5, 35 .....61
  - c) Claims 16-23, 26-34 .....63
  - d) Claims 36-40.....64

<b>B.</b>	<b>All Challenged Claims Are Not Enabled .....</b>	<b>65</b>
1.	<i>Claims 1-2, 6-15, and 24-25 Are Not Enabled.....</i>	68
a)	Extreme Scope of the Claims .....	68
b)	Limited Working Examples and Only a Research Plan for Discovering Active Mutant PH20 Polypeptides.....	70
c)	Making Multiple Changes to PH20 Polypeptides Was Unpredictable.....	73
d)	Other Wands Factors and Conclusion .....	76
2.	<i>Dependent Claims 3-5, 16-23, and 26-40 Are Not Enabled.....</i>	77
a)	Claims 3-4.....	77
b)	Claims 5, 35 .....	78
c)	Claims 16-23, 26-34 .....	78
d)	Claims 36-40.....	79
<b>C.</b>	<b>Inactive PH20 Polypeptides Are Not Useful and Do Not Remedy the § 112(a) Deficiencies of the Claims.....</b>	<b>81</b>
<b>D.</b>	<b>The Original Claims of the '731 Application Do Not Cure the Written Description and Enablement Deficiencies .....</b>	<b>84</b>
<b>VI.</b>	<b>Challenged Claims 1-2, 5-40 Are Unpatentable Under § 103 .....</b>	<b>85</b>
<b>A.</b>	<b>The Prior Art .....</b>	<b>85</b>
<b>B.</b>	<b>Because D320K and D320S PH20<sub>1-447</sub> Would Have Been Obvious, Claims 1-2, 6-15, and 24-25 Are Unpatentable.....</b>	<b>86</b>
1.	<i>Patentee's '429 Patent Motivates a Skilled Artisan to Make Single Amino Acid Substitutions in Non-Essential Regions of PH20<sub>1-447</sub> .....</i>	86
2.	<i>Chao Provides Information Useful for Engineering the Changes to PH20<sub>1-447</sub> that the '429 Patent Suggests .....</i>	89
3.	<i>A Skilled Artisan Would Have Identified Position 320 as Being in a Non-Essential Region of PH20<sub>1-447</sub> in 2011.....</i>	93
4.	<i>A Skilled Artisan Would Have Viewed Lysine and Serine as Obvious Single Amino Acid Substitutions for Aspartic Acid at Position 320 of PH20<sub>1-447</sub>.....</i>	95

5. *A Skilled Artisan Would Have Reasonably Expected the D320K and D320S Substitutions in PH20<sub>1-447</sub> to Yield Enzymatically Active PH20 Proteins*..... 100

    a) Patent Owner Cannot Contradict Its Past Representations to the PTO..... 100

    b) Skilled Artisans Would Reasonably Expect D320K and D320S Substitutions to be Tolerated in PH20<sub>1-447</sub>..... 101

    c) A PH20 Structural Model Confirms that PH20<sub>1-447</sub> Would Tolerate Lysine and Serine at Position 320..... 102

**C. Dependent Claims 5, 16-23, and 26-40 Are Obvious .....109**

    1. *Claims 5, 35* ..... 109

    2. *Claims 16-18*..... 110

    3. *Claims 19-22, 33-34*..... 111

    4. *Claims 23, 26-32, 36-40*..... 112

**D. There Is No Nexus Between the Claims and Any Evidence of Putative Secondary Indicia.....115**

**VII. The Board Should Not Exercise Its Discretion Under § 324(a) or § 325(d).....116**

**VIII. CONCLUSION .....117**

**TABLE OF AUTHORITIES**

	<b>Page(s)</b>
<b>Cases</b>	
<i>AbbVie Deutschland GmbH &amp; Co., KG v. Janssen Biotech, Inc.</i> , 759 F.3d 1285 (Fed. Cir. 2014) .....	27, 28, 29
<i>ABS Glob., Inc. v. Inguran</i> , 914 F.3d 1054 (7th Cir. 2019) .....	81
<i>Amgen Inc. v. Sanofi</i> , 598 U.S. 594 (2023).....	<i>passim</i>
<i>Apple Inc. v. Fintiv, Inc.</i> , IPR2020-00019, Paper 11 (P.T.A.B. Mar. 20, 2020).....	116
<i>Ariad Pharms., Inc. v. Eli Lilly &amp; Co.</i> , 598 F.3d 1336 (Fed. Cir. 2010) ( <i>en banc</i> ) .....	26, 28, 85
<i>Atlas Powder Co. v. E.I. du Pont de Nemours &amp; Co.</i> , 750 F.2d 1569 (Fed. Cir. 1984) .....	83
<i>Baxalta Inc. v. Genentech, Inc.</i> , 579 F. Supp. 3d 595 (D. Del. 2022), <i>aff'd</i> , 81 F.4th 1362 (Fed. Cir. 2023) .....	67, 73
<i>Boehringer Ingelheim Animal Health USA Inc. v. Kan. State Univ. Research Found.</i> , PGR2020-00076, Paper 42 (P.T.A.B. Jan. 31, 2022).....	30, 64
<i>Collegium Pharm., Inc. v. Purdue Pharma L.P.</i> , 2021 WL 6340198 (P.T.A.B. Nov. 19, 2021), <i>aff'd</i> , <i>Purdue Pharma L.P. v. Collegium Pharm., Inc.</i> , 86 F.4th 1338 (Fed. Cir. 2023) .....	4
<i>Fiers v. Revel</i> , 984 F.2d 1164 (Fed. Cir. 1993) .....	85
<i>Gentry Gallery, Inc. v. Berkline Corp.</i> , 134 F.3d 1473 (Fed. Cir. 1998) .....	59

*Idenix Pharm., LLC v. Gilead Scis., Inc.*,  
 941 F.3d 1149 (Fed. Cir. 2019) .....*passim*

*Inguran, LLC v. Premium Genetics (UK) Ltd.*,  
 Case PGR2015-00017, Paper 8 (P.T.A.B. Dec. 22, 2015).....4

*Intex Recreation Corp. v. Team Worldwide Corp.*,  
 2020 WL 2071543 (P.T.A.B. Apr. 29, 2020) .....5

*Janssen Pharmaceutica N.V. v. Teva Pharms. USA, Inc.*,  
 583 F.3d 1317 (Fed. Cir. 2009) .....84

*McRO, Inc. v. Bandai Namco Games Am. Inc.*,  
 959 F.3d 1091 (Fed. Cir. 2020) .....73, 78

*Pharm. Res., Inc. v. Roxane Labs., Inc.*,  
 253 F. App’x. 26 (Fed. Cir. 2007) .....83

*Rasmusson v. SmithKline Beecham Corp.*,  
 413 F.3d 1318 (Fed. Cir. 2005) .....83

*TIP Sys., LLC v. Phillips & Brooks/Gladwin, Inc.*,  
 529 F.3d 1364 (Fed. Cir. 2008) .....21

*US Endodontics, LLC v. Gold Standard Instruments, LLC*,  
 PGR2015-00019, Paper 17 (P.T.A.B. Jan. 29, 2016).....4

*In re Wands*,  
 858 F.2d 731 (Fed. Cir. 1988) .....66, 68, 70, 76

*Wyeth & Cordis Corp. v. Abbott Labs*,  
 720 F.3d 1380 (Fed. Cir. 2013) .....66, 73

**Statutes**

35 U.S.C. § 103 .....7, 85

35 U.S.C. § 112 .....7, 25, 85

35 U.S.C. § 120 .....1, 5

35 U.S.C. § 121 .....5

## I. Introduction

Petitioner Merck Sharp & Dohme LLC (“Merck”) requests post grant review of U.S. Patent No. 12,049,652 (“’652 Patent”).

Claims 1-40 of the ’652 Patent claims are unpatentable for three independent reasons. The first two are linked to their extreme breadth. By claiming any enzymatically active modified human PH20 polypeptide that (i) *must have* one amino acid substitution at position 320, and (ii) *may have* between 20 and 41 additional substitutions at *any* of 430+ positions, and to *any* of 19 other amino acids, the claims capture between  $10^{59}$  and  $10^{112}$  distinct polypeptides. The scale of these genera is unfathomable. The collective weight of one of each polypeptide in the smallest genus exceeds the weight of the Earth, and practicing the full scope of the narrowest claimed genus would require many lifetimes of “making and testing” using the patent’s methodology.

The immensely broad claims, measured against the common disclosure of the ’652 Patent and its ultimate parent ’731 Application,<sup>1</sup> utterly fail the written description and enablement requirements of § 112(a). That renders every claim of the ’652 Patent unpatentable. It also precludes the claims from a valid § 120

---

<sup>1</sup> 13/694,731 (’731 Application) (EX1026).

benefit claim to the '731 Application, the only non-provisional application filed before March 16, 2013, thus making the '652 Patent PGR eligible.

Regarding written description, the common disclosure makes no effort to identify (and never contends there is) a common structure shared by the enzymatically active, multiply-modified PH20 polypeptides within each claimed genus. The disclosed examples also are not representative: each example has only *one* amino acid substitution in *one* PH20 sequence (1-447), but the claims encompass PH20 proteins with myriad *undescribed* combinations of 5, 10, 15, or 20+ substitutions anywhere within PH20 sequences of varying length. The claims even capture mutated PH20 polypeptides the disclosure says to avoid (*e.g.*, PH20<sub>1-447</sub> mutants rendered inactive by a single substitution, inactive truncated forms). The disclosure is nothing more than a research plan, lacking any blaze marks, and does not describe the claimed genera.

Regarding enablement, equally fatal problems exist: the disclosure identifies *no* enzymatically active modified PH20 with 2 or more substitutions, much less affirmatively guides the selection of *which* combinations of substitutions yield such enzymes. The only process it discloses for making multiply-substituted PH20 mutants is prophetic, and requires the “trial-and-error discovery” methodology the Supreme Court found incapable of enabling a much smaller genus of

polypeptides.<sup>2</sup> And practicing the full scope of the claims requires scientists to repeat this “make-and-test” methodology innumerable times until they had made and tested between  $10^{59}$  and  $10^{112}$  unique proteins. That is far more than undue experimentation—it is impossible.

Finally, claims 1-2 and 5-40 are unpatentable because each captures at least one obvious PH20<sub>1-447</sub> mutant having a single substitution at position 320. But Patentee’s ’429 Patent (EX1005) directs artisans to make single amino acid substitutions in non-essential regions of PH20<sub>1-447</sub> (and expressly claimed them). Skilled artisans implementing that guidance in 2011 would have found Chao (EX1006)—a 2007 paper ignored in the common disclosure and never cited. Using their knowledge and the collective teachings of Chao and the ’429 Patent, they would have (i) readily identified position 320 as being in a non-essential region of PH20, (ii) found it obvious to change aspartic acid at position 320 to lysine or serine, and (iii) reasonably expected both mutants to retain enzymatic activity because that is what Patentee said in its ’429 Patent (“Those of skill in this art recognize that, in general, single amino acid substitutions in non-essential regions of a polypeptide do not substantially alter biological activity”).<sup>3</sup> Because the

---

<sup>2</sup> *Amgen Inc. v. Sanofi*, 598 U.S. 594, 614 (2023).

<sup>3</sup> EX1005, 16:17-22.

claims capture these obvious mutants, as well as obvious compositions and uses of them, they are unpatentable.

The '652 Patent claims are unpatentable. The Board should institute trial.

## **II. Compliance with PGR Requirements**

### **A. Certification of Standing**

Petitioner certifies this Petition is filed within 9 months of the '652 Patent's issuance. Petitioner certifies it is not barred or estopped from requesting this PGR. Petitioner and its privies have not filed a civil action challenging the validity of any claim of the '652 Patent.

The '652 Patent is eligible for post-grant review because at least one of its claims is not entitled to an effective filing date prior to March 16, 2013.

A patent is PGR eligible if it issued from an application filed after March 16, 2013 “if the patent contains ... at least one claim that was not disclosed in compliance with the written description and enablement requirements of § 112(a) in the earlier application for which the benefit of an earlier filing date prior to March 16, 2013 was sought.” *See Inguran, LLC v. Premium Genetics (UK) Ltd.*, Case PGR2015-00017, Paper 8 at 16-17 (P.T.A.B. Dec. 22, 2015); *US Endodontics, LLC v. Gold Standard Instruments, LLC*, PGR2015-00019, Paper 17 at 8 (P.T.A.B. Jan. 29, 2016); *Collegium Pharm., Inc. v. Purdue Pharma L.P.*, 2021 WL 6340198, at \*14-18 (P.T.A.B. Nov. 19, 2021) (same) *aff'd Purdue*

*Pharma L.P. v. Collegium Pharm., Inc.*, 86 F.4th 1338, 1346 (Fed. Cir. 2023);  
*Intex Recreation Corp. v. Team Worldwide Corp.*, 2020 WL 2071543, at \*26  
(P.T.A.B. Apr. 29, 2020) (same).

Only one of the applications to which the '652 Patent claims benefit under 35 U.S.C. § 120 and/or § 121—U.S. Application No. 13/694,731 (the '731 Application)—was filed before March 16, 2013. That application, issued as U.S. Patent No. 9,447,401 (EX1025), claims priority to two provisional applications (61/631,313, filed November 1, 2012 and 61/796,208, filed December 30, 2011) and WO 01/3087 (“WO087”). The '731 Application, however, alters several passages of the provisional disclosures, adds new examples and tested mutants and makes other changes.<sup>4</sup>

The '731 Application (including subject matter incorporated by reference) does not provide written description support for and does not enable any claim of the '652 Patent (§§ V.A, V.B). The same is true for the '652 Patent, whose disclosure relative to the claims is generally the same as the '731 Application.<sup>5</sup>

---

<sup>4</sup> EX1026, 153:15-163:26, 324-34, 19:25-26, 28; EX1051; EX1052.

<sup>5</sup> The “common disclosure” refers to the shared disclosure of the '652 Patent and the '731 Application (EX1026). Citations are to the '652 Patent; EX1015

The '652 Patent is PGR eligible as at least one of its claims does not comply with § 112(a) based on the '731 Application filed before March 16, 2013.

**B. Mandatory Notices**

**1. Real Party-in-Interest**

Merck Sharp & Dohme LLC is the real party-in-interest for this Petition.

**2. Related Proceedings**

PGR2025-00003, PGR2025-00004, PGR2025-00006, PGR2025-00009, PGR2025-00017, PGR2025-00024, and PGR2025-00030 are related proceedings.

**3. Counsel and Service Information**

Lead Counsel Jeffrey P. Kushan Reg. No. 43,401 Sidley Austin LLP 1501 K Street, N.W. Washington, D.C. 20005 <a href="mailto:jkushan@sidley.com">jkushan@sidley.com</a> (202) 736-8914	Backup Counsel Leif Peterson Pro Hac Vice forthcoming Sidley Austin LLP 1 S Dearborn Street Chicago, IL 60603 <a href="mailto:leif.peterson@sidley.com">leif.peterson@sidley.com</a> (312) 853-7190	Backup Counsel Mark Stewart Reg. No. 43,936 Merck Sharp & Dohme LLC 126 E. Lincoln Ave. Rahway, New Jersey 07065 <a href="mailto:Mark.stewart@merck.com">Mark.stewart@merck.com</a> (732) 594-6302
--	--	---

Petitioner consents to service via e-mail at the email addresses listed above.

**III. Grounds**

The grounds advanced in this Petition are:

---

correlates citations to the '731 Application. The disclosures are highly similar but not identical. *See* EX1068, ¶ 6.

- (a) Claims 1-40 are unpatentable under 35 U.S.C. § 112 as lacking adequate written description.
- (b) Claims 1-40 are unpatentable under 35 U.S.C. § 112 as not being enabled.
- (c) Claims 1-2, 5-40 are unpatentable as obvious under 35 U.S.C. § 103 based on the '429 Patent (EX1005), Chao (EX1006), and knowledge held by a person of ordinary skill in the art.

Petitioner's grounds are supported by the evidence submitted with this Petition, including testimony from Dr. Michael Hecht (EX1003) and Dr. Sheldon Park (EX1004).

In this Petition, "PH20" refers to the human PH20 hyaluronidase protein. The full-length PH20 protein (SEQ ID NO: 6) includes a 35 amino acid signal sequence, yielding position numbers in mature forms of PH20 that differ from SEQ ID NO: 6 by 35 residues.<sup>6</sup> The annotation "PH20<sub>1-n</sub>" refers to a sequence of 1-n residues in PH20 (*e.g.*, PH20<sub>1-447</sub> is SEQ ID NO: 3), and "AxxxB" is used to identify the position of a substitution (*e.g.*, "D320K").

---

<sup>6</sup> EX1003, ¶ 15.

#### **IV. Background on the '652 Patent**

##### **A. Field of the Patent**

The '652 Patent concerns the human PH20 hyaluronidase enzyme and structurally altered forms of that protein that retain enzymatic activity.<sup>7</sup>

##### **1. Protein Structures**

Proteins are comprised of sequences of amino acids. A protein's activity, however, derives from its unique, three-dimensional shape—its structure.<sup>8</sup> That is dictated by specific and often characteristic patterns of amino acids in its sequence, which induce formation and maintenance of various secondary structures and structural motifs, which are packed into compact domains that define the protein's overall structure (tertiary structure).<sup>9</sup>

---

<sup>7</sup> EX1001, 4:20-23.

<sup>8</sup> EX1003, ¶ 36.

<sup>9</sup> EX1014, 3-4, 24-32, Figure 1.1; EX1039, 136-37 (Figure 3-11); EX1003, ¶¶ 36-40.

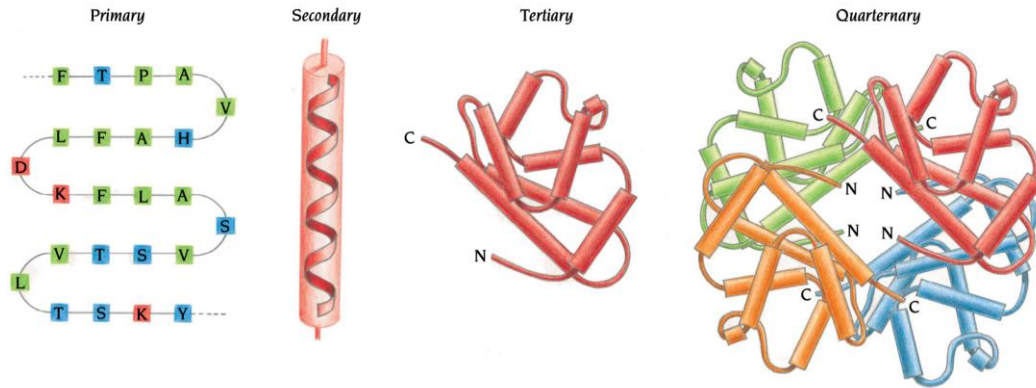

Secondary structures, such as  $\alpha$ -helices or  $\beta$ -strands, are formed and stabilized by different but characteristic patterns of amino acids (below).<sup>10</sup>

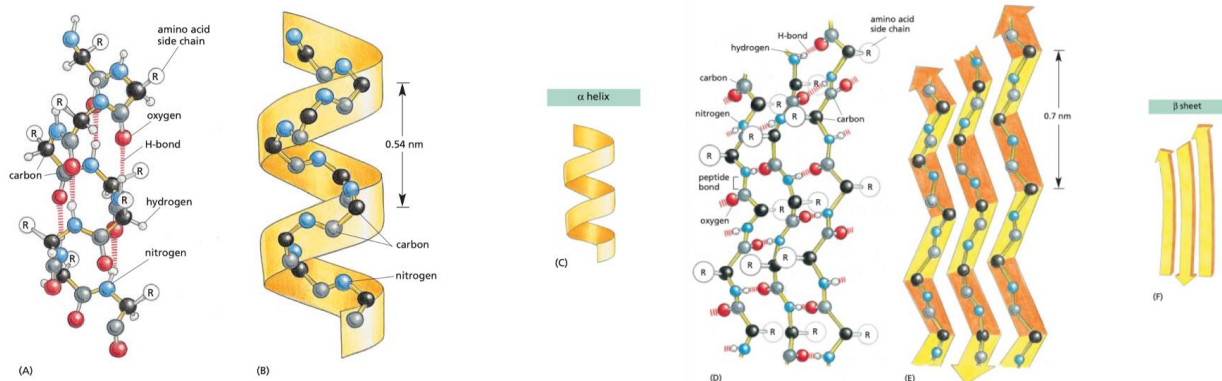

**Figure 3-7** The regular conformation of the polypeptide backbone in the  $\alpha$  helix and the  $\beta$  sheet. <GTAG> <TGCT> (A, B, and C) The  $\alpha$  helix. The N-H of every peptide bond is hydrogen-bonded to the C=O of a neighboring peptide bond located four peptide bonds away in the same chain. Note that all of the N-H groups point up in this diagram and that all of the C=O groups point down (toward the C-terminus); this gives a polarity to the helix, with the C-terminus having a partial negative and the N-terminus a partial positive charge. (D, E, and F) The  $\beta$  sheet. In this example, adjacent peptide chains run in opposite (antiparallel) directions. Hydrogen-bonding between peptide bonds in different strands holds the individual polypeptide chains (strands) together in a  $\beta$  sheet, and the amino acid side chains in each strand alternately project above and below the plane of the sheet. (A) and (D) show all the atoms in the polypeptide backbone, but the amino acid side chains are truncated and denoted by R. In contrast, (B) and (E) show the backbone atoms only, while (C) and (F) display the shorthand symbols that are used to represent the  $\alpha$  helix and the  $\beta$  sheet in ribbon drawings of proteins (see Panel 3-2B).

<sup>10</sup> EX1039, 134; EX1014, 14-22, Figures 2.2, 2.5, Table 2.1; EX1047, 2031-32; EX1003, ¶¶ 40-43.

Intervening sequences between those characteristic sequences are important too; they direct and facilitate positioning and arrangement of the various secondary structures into structural motifs and the protein's tertiary structure.<sup>11</sup>

Changes to a protein's amino acid sequence can affect the folding, formation and stability of these various structures that define the protein's overall shape. For example, changing even a single residue known to be critical to the protein's structure or activity can render a protein inactive.<sup>12</sup>

Making many concurrent changes to a protein's sequence can cause myriad effects on the protein's structure, especially when they are in or affect the same region(s) of the protein.<sup>13</sup> For example, it can disrupt the characteristic patterns, spacing and/or types of amino acids required to induce formation and stability of secondary structures, and disrupt folding and positioning of the secondary structures and structural motifs into the protein's tertiary structure.<sup>14</sup> Multiple changes in different regions of the amino acid sequence also cause unfavorable

---

<sup>11</sup> EX1003, ¶¶ 44-46; EX1014, 21-22.

<sup>12</sup> EX1003, ¶¶ 54, 153; EX1004, ¶¶ 20, 25.

<sup>13</sup> EX1003, ¶ 161.

<sup>14</sup> EX1003, ¶¶ 55-56, 145; EX1047, 6349; EX1046, 2034; *see also* EX1040, 14412-13; EX1041, 21149-50; EX1042, 1-3.

spatial interactions that destabilize or impair folding.<sup>15</sup> Consequently, in 2011, predicting the effects of the myriad interactions that may be disrupted by multiple concurrent substitutions was beyond the capacity of skilled artisans and available computational tools.<sup>16</sup>

## 2. Hyaluronidase Enzymes

PH20 is one of five structurally similar human hyaluronidases and is homologous—evolutionarily related to—hyaluronidases in many species.<sup>17</sup> PH20 breaks down hyaluronan (“HA”) by selectively hydrolyzing glycosidic linkages.<sup>18</sup> PH20 exists naturally as a GPI anchored protein; deletion of its GPI-anchoring sequence yields a soluble, neutral active enzyme.<sup>19</sup>

---

<sup>15</sup> EX1003, ¶¶ 57-59.

<sup>16</sup> EX1003, ¶¶ 50, 161, 199, 239; EX1004, ¶¶ 160-162.

<sup>17</sup> EX1007, 10:18-30; EX1006, 6911, 6916 (Figure 3); EX1003, ¶¶ 33, 77.

<sup>18</sup> EX1003, ¶ 77; EX1008, 819.

<sup>19</sup> EX1005, 2:40-61, 87:52-88:24; EX1013, 430-32, Figure 2; EX1003, ¶¶ 92, 206; EX1029, 546, Figure 1.

Before 2011, many essential residues in PH20 were known. Several are in the shared catalytic site of the protein;<sup>20</sup> mutating certain residues in or near that site can abolish enzymatic activity.<sup>21</sup> Conserved cysteine residues that stabilize the protein structure are also essential,<sup>22</sup> as are certain conserved asparagine residues involved in glycosylation.<sup>23</sup>

In 2007, Chao reported an experimentally determined structure of the human HYAL1 hyaluronidase, and used an alignment of the five human hyaluronidases to illustrate shared secondary structures and conserved residues in these proteins.<sup>24</sup> Among its findings was that human hyaluronidases contain a unique structure—the Hyal-EGF domain.<sup>25</sup> Using its sequence analysis, an earlier structure of bee

---

<sup>20</sup> EX1006, 6914-16, Figure 3; EX1007, 35:28-36:10; EX1011, 810-14; EX1008, 824-25; EX1009, 6912-17.

<sup>21</sup> EX1011, 812-14; EX1010, 9435-39, Table 1.

<sup>22</sup> EX1006, 6914-16, Figure 3; EX1011, 810-11; EX1005, 88:21-22.

<sup>23</sup> EX1005, 7:9-27; EX1007, 36:12-20; EX1010, 9433, 9435-40.

<sup>24</sup> EX1006, 6914-18.

<sup>25</sup> EX1006, 6916-18; EX1010, 9439-40; EX1003, ¶¶ 84-88; EX1004, ¶¶ 97-99.

venom hyaluronidase and a computer model of the protein structures, Chao identified residues in the catalytic site that interact with HA.<sup>26</sup>

### 3. Protein Engineering

In 2011, skilled artisans used two general approaches to engineer changes into proteins.<sup>27</sup> In “rational design,” skilled artisans employed computational tools—sequence alignments and protein structure models—to study the protein and then select where and what changes to introduce.<sup>28</sup> For example, a “multiple-sequence alignment” (“MSA”)<sup>29</sup> produced by aligning known sequences of homologous, naturally occurring proteins identifies positions with no or little amino acid variation (“conserved” / “essential” residues) and positions where different amino acids occur (“non-conserved” / “non-essential” residues).<sup>30</sup> A

---

<sup>26</sup> EX1006, 6912-13, 6916-18, Figures 2C, 4A; EX1033, 1028-29, 1035; EX1010, 9434, 9436, Figure 1.

<sup>27</sup> EX1003, ¶ 47.

<sup>28</sup> EX1016, 181-82; EX1017, 223, 236; EX1003, ¶¶ 48-50.

<sup>29</sup> EX1017, 224-27; EX1016, 181-86 (Figure 1); EX1003, ¶¶ 48-50; EX1004, ¶¶ 22-23, 29.

<sup>30</sup> EX1003, ¶¶ 223-24; EX1004, ¶¶ 21-22, 25, 30-31; EX1016, 181-84; EX1017, 224-25; EX1014, 351.

structural model using the protein's sequence but based on a known structure of a homologous protein enabled assessment of interactions between amino acids at a particular positions.<sup>31</sup> In 2011, using rational design techniques, a skilled artisan could assess, with varying effort, effects of changing one or a few amino acids, but could not use those techniques to predict the effects of many concurrent changes, given the escalating complexity of numerous, interrelated interactions (which exponentially increase with the number of changes) and the limits of protein modeling tools.<sup>32</sup>

“Directed evolution” techniques arose due to the limits of rational design.<sup>33</sup> They use “trial-and-error” experiments to find mutants with randomly distributed changes that exhibit desired properties, but require creation and screening of large libraries of mutants, each with one amino acid randomly changed at one position in its sequence.<sup>34</sup> Importantly, until a desired mutant is made, found, and tested,

---

<sup>31</sup> EX1017, 228-30; EX1031, 461, 463, 469-71; EX1014, 351-52; EX1032, 265-66; EX1004, ¶ 37; *also id.* 33-36; EX1003, ¶¶ 234, 236.

<sup>32</sup> EX1003, ¶¶ 50, 161; EX1004, ¶¶ 160-162.

<sup>33</sup> EX1003, ¶ 51; EX1059, 1225-26; EX1018, 378.

<sup>34</sup> EX1003, ¶ 51; EX1059, 1225-26; EX1018, 378.

whether it exists and its sequence are unknown.<sup>35</sup> Sophisticated assays that rapidly and precisely identify mutants with desired properties are critical, given the scale of experimentation this approach requires.<sup>36</sup> The '652 Patent embodies this approach.<sup>37</sup>

### **B. Person of Ordinary Skill in the Art**

While the '652 Patent claims priority to provisional applications dating to December 30, 2011 and benefit to the '731 Application (filed December 28, 2012), they are not supported as § 112(a) requires by those earlier-filed applications. *See* §§ II.A, V.A, V.B. Regardless, the obviousness grounds rely on prior art published before and knowledge/perspectives of a skilled artisan before December 2011.

In 2011, a person of ordinary skill in the art would have had an undergraduate degree, a Ph.D., and post-doctoral experience in scientific fields relevant to study of protein structure and function (*e.g.*, chemistry, biochemistry, biology, biophysics). From training and experience, the person would have been familiar with factors influencing protein structure, folding and activity, production of modified proteins using recombinant DNA techniques, and use of biological

---

<sup>35</sup> EX1003, ¶ 193.

<sup>36</sup> EX1003, ¶¶ 52-53.

<sup>37</sup> EX1003, ¶¶ 141, 182, 192, 196.

assays to characterize protein function, as well with techniques used to analyze protein structure (*i.e.*, sequence searching and alignments, protein modeling software, etc.).<sup>38</sup>

### **C. Prosecution History**

No issues relevant to the present grounds were raised during examination of the '652 Patent. In the sole Office action, indefiniteness rejections were imposed (*e.g.*, unclear references to “modifications” and an improper dependent claim),<sup>39</sup> which Patentee overcame with claim amendments.<sup>40</sup> Non-statutory double patenting rejections were also imposed,<sup>41</sup> which Patentee overcame with terminal disclaimers.<sup>42</sup>

### **D. The Challenged Claims**

The claim terms are either expressly defined in the common disclosure or are used with their common and ordinary meaning. Consequently, no term requires an express construction to assess the grounds in this Petition.

---

<sup>38</sup> EX1003, ¶ 13.

<sup>39</sup> EX1002, 1240-41.

<sup>40</sup> EX1002, 1280-81.

<sup>41</sup> EX1002, 1242-45.

<sup>42</sup> EX1002, 1280.

A clear understanding of the *breadth* of the claims, however, is important, as it shows that each claim captures a massive genus of structurally distinct mutant PH20 polypeptides that is neither adequately described in nor enabled by the common disclosure of the '731 Application and the '652 Patent.

**1. The Claims Encompass a Staggering Number of Modified PH20 Polypeptides**

The claims define an incredibly broad and diverse genus of “modified PH20 polypeptides,” which the common disclosure defines as “a PH20 polypeptide that contains at least one amino acid modification, such as at least one amino acid replacement ... in its sequence of amino acids compared to a reference unmodified PH20 polypeptide.”<sup>43</sup>

Claim 1 defines the genus as containing modified PH20 polypeptides that:

- ***must*** contain ***one*** amino acid replacement at position 320 (*i.e.*, from D to any of H, K, R, and S); and
- ***may*** contain ***additional*** modifications, provided each polypeptide retains ***at least 91% sequence identity*** to one of 37 unmodified sequences (SEQ ID NOs: 3, 7, or 32-66), ranging in length from 430 (SEQ ID NO: 32) to 474 residues (SEQ ID NO: 7).

Certain dependent claims restrict these parameters:

---

<sup>43</sup> EX1001, 48:41-46.

- (i) claims 2 and 24-25 limit (*inter alia*) sequence identity to 95%,
- (ii) claims 8-15 and 24-25 narrow the comparator sequences (*e.g.*, omit SEQ ID NO: 7, require SEQ ID NOs: 35 or 32, or list SEQ ID NOs: 618-620),
- (iii) certain claims require the position 320 substitutions to be K (6, 9, 12-13, 15, 24-25) or S (7), and
- (iv) claims 3-5 add functional requirements (*e.g.*, increased “stability” or activity, solubility).

Claims 16-23 and 26-40 depend from claim 1 but do not alter the parameters governing the number of PH20 polypeptides in each genus. Claims 16-22 specify additional features of the PH20 polypeptides while claims 23 and 26-40 define pharmaceutical compositions and methods of treatment or of increasing delivery of another therapeutic agent.

The specification explains that “sequence identity can be determined by standard alignment algorithm programs ...”<sup>44</sup> and provides an example, explaining a polypeptide that is “‘at least 90% identical to’ refers to percent identities from 90 to 100% relative to the reference polypeptide” where “no more than 10% (*i.e.*, 10

---

<sup>44</sup> EX1001, 60:11-13.

out of 100) of amino acids [] in the test polypeptide [] differs from that of the reference polypeptides.”<sup>45</sup>

It further explains that “differences can be represented as point mutations randomly distributed over the entire length of an amino acid sequence” and that “[d]ifferences are defined as [] amino acid substitutions, insertions or deletions.”<sup>46</sup> Also, “amino acids selected to replace the target positions on the particular protein being optimized can be either all of the remaining 19 amino acids, or a more restricted group containing only selected amino acids” (*e.g.*, 10-18 of the 19 alternative amino acids).<sup>47</sup> Except for position 320, no language in the claims restricts *where* substitutions can occur within the modified PH20 sequence, or *which* of 19 other amino acids can be substituted at those positions.

The sequence identity parameters capture an immense number of modified PH20 polypeptides, each with a unique amino acid sequence.<sup>48</sup> The polypeptides may have up to 21-42 total changes but must have one substitution at position 320.

---

<sup>45</sup> EX1001, 60:47-56.

<sup>46</sup> EX1001, 60:57-65; *see also id.* at 5:5-6, 47:46-50, 59-61.

<sup>47</sup> EX1001, 130:25-32; *see also id.* at 135:42-44.

<sup>48</sup> EX1003, ¶¶ 123, 125.

Several claims permit four position 320 alternatives (H, K, R, S) while others permit one (K or S) (calculations shown below):<sup>49</sup>

Claims	Max Length	Sequence Identity %	Max Changes	Pos. 320 Choices	# of Distinct Polypeptides
1, 3-5, 16-23, 26-40	474	91	42	4	$2.53 \times 10^{112}$
2	474	95	23	4	$2.07 \times 10^{66}$
6-7	474	91	42	1	$6.32 \times 10^{111}$
8	465	91	41	4	$5.65 \times 10^{109}$
9	465	91	41	1	$1.41 \times 10^{109}$
10	433	91	38	4	$4.01 \times 10^{101}$
11	430	91	38	4	$3.06 \times 10^{101}$
12	433	91	38	1	$1.00 \times 10^{101}$
13	430	91	38	1	$7.66 \times 10^{100}$
14	447	91	40	4	$5.58 \times 10^{106}$
15	447	91	40	1	$1.40 \times 10^{106}$
24	430	95	21	1	$4.40 \times 10^{59}$
25	433	95	21	1	$5.08 \times 10^{59}$

## 2. The Claims Encompass Particular Mutants: D320K or D320S PH20<sub>1-447</sub>

Claims 1-40 capture a modified PH20<sub>1-447</sub> polypeptide that changes only one amino acid: aspartic acid at position 320 to either lysine (K) (“D320K”) or serine

<sup>49</sup> EX1004, ¶¶ 168-172, Appendix F.

(S) (“D320S”). These single-replacement PH20<sub>1-447</sub> mutants are: (i) 99.7% identical to SEQ ID NO: 3 (1 change / 447 residues), (ii) 96.5% identical to SEQ ID NO: 35 (15 changes / 433 residues), and (iii) 95.9% identical to SEQ ID NO: 32 (18 changes / 430 residues).<sup>50</sup>

### 3. The Claims Are Restricted to One of Two Alternative Embodiments in the Patents: “Active Mutants”

When a specification discloses alternative embodiments, the claim language may limit the claims to one.<sup>51</sup> That is true here: the specification describes two mutually exclusive categories of “modified PH20 polypeptides” (*i.e.*, “active mutants” vs. “inactive mutants”) but the claims are limited to one (*i.e.*, “active mutants”).

According to the specification:

- “*Active mutants*” are modified PH20 polypeptides that “exhibit at least 40% of the hyaluronidase activity of the corresponding PH20

---

<sup>50</sup> EX1003, ¶ 139.

<sup>51</sup> *TIP Sys., LLC v. Phillips & Brooks/Gladwin, Inc.*, 529 F.3d 1364, 1375 (Fed. Cir. 2008).

polypeptide not containing the amino acid modification (*e.g.*, amino acid replacement).”<sup>52</sup>

- “*Inactive mutants*” are modified PH20 polypeptides that “generally exhibit less than 20% ... of the hyaluronidase activity of a wildtype or reference PH20 polypeptide, such as the polypeptide set forth in SEQ ID NO: 3 or 7.”<sup>53</sup>

Mutants are then classified into tables of “active” or “inactive” mutants using the >40% threshold (Tables 3 and 9) or <20% threshold (Tables 5 and 10).<sup>54</sup>

The common disclosure reports no examples of an “active mutant” modified PH20 with two or more replacements.<sup>55</sup> It also reports no examples of an enzymatically active PH20<sub>1-447</sub> that incorporates: (i) a mutation that preserved

---

<sup>52</sup> EX1001, 75:47-52; *see also id.* at 79:29-33 (“active mutants” “can exhibit 40% to 5000% of the hyaluronidase activity of a wildtype or reference PH20 polypeptide ...”); *id.* at 79:26-29.

<sup>53</sup> EX1001, 115:58-67. *See also id.* at 261:61-65 (mutants with <20% activity “were rescreened to confirm that the dead mutants are inactive” in Table 10).

<sup>54</sup> EX1001, 80:60-82:10, 227:5-7, 116:58-118:7, 262:21-24 (“reconfirmed inactive mutants are set forth in Table 10.”); EX1003 ¶¶ 101, 103-104, 110.

<sup>55</sup> *E.g.*, EX1003, ¶¶ 144, 181.

activity in Tables 3 and 9 (“active mutants”) *plus* (ii) a second mutation that eliminated activity in Tables 5 and 10 (“inactive mutants”).

The specification also portrays “active” and “inactive” mutants as having distinct utilities requiring mutually exclusive properties.

- “Active mutants” are portrayed as being therapeutically useful *because they possess hyaluronidase activity*.<sup>56</sup>
- “Inactive mutants” are portrayed as being therapeutically useful *because they lack hyaluronidase activity*.<sup>57</sup>

The only utility identified for inactive mutants is “as antigens in contraception vaccines,” which, while implausible (*see* § V.C), only requires them to lack activity. “Active mutants” also are not portrayed as having contraceptive utility; they are used *in combination* with contraceptive agents.<sup>58</sup>

The claim language reinforces that each is limited to “active mutants.”

---

<sup>56</sup> EX1001, 174:18-24; *see also id.* at 4:37-40, 73:33-47, 174:18-187:47; EX1003, ¶ 111.

<sup>57</sup> EX1001, 72:60-62; *see also id.* at 187:48-49, 75:56-58, 187:47-67 (for “contraception” “the modified PH20 polypeptides can be inactive enzymes, such as any described in Sections C.2.”); EX1003, ¶ 112.

<sup>58</sup> EX1001, 150:42-55; EX1060, 1711.

First, each requires modified PH20 polypeptides with one of four replacements at position 320 that yielded an “active mutant” as a single-replacement PH20<sub>1-447</sub> polypeptide (*i.e.*, D320H, D320K, D320R, or D320S). All four are identified as “Active Mutants” in Table 3 and all have >100% activity per Table 9.<sup>59</sup>

Second, claim 4 restricts the genus of “active mutants” in claim 1 (*i.e.*, those with some hyaluronidase activity) to those with least 100% of the activity of unmodified PH20.<sup>60</sup>

Third, the specification defines a “modified PH20 polypeptide” as “a PH20 polypeptide that contains at least one amino acid modification,” but can also “have up to 150 amino acid replacements, so long as the resulting modified PH20 polypeptide *exhibits hyaluronidase activity.*”<sup>61</sup> This aligns with the specification’s

---

<sup>59</sup> EX1001, 85 (Table 3), 252 (Table 9), 97:49-61; EX1003, ¶¶ 129-131.

<sup>60</sup> Claim 3 requires mutants with increased resistance to or stability in denaturing conditions. The specification portrays increased stability as an additional attribute of an “active mutant.” EX1001, 52:44-50, 127:25-44, 173:6-9, 302:36-303:56.

<sup>61</sup> EX1001, 48:41-56; *see also id.* at 47:64-48:1, 76:5-8, 76:67-77:7, 81:1-82:10; EX1003, ¶ 132.

prophetic methodology for discovering PH20 polypeptides with multiple changes, which selects “active mutants” with one substitution, randomly introduces another, and then screens to find “double mutants” that *retained* hyaluronidase activity.<sup>62</sup>

This also tracks the claims, which require one substitution and permit others.

Patentee may contend the claims should be read as encompassing both alternative embodiments (*i.e.*, “active” and “inactive” mutants). Reading the claims in that manner is incorrect. It also exacerbates the § 112 problems, as every claim still necessarily includes (and thus must describe and enable) the full sub-genus of “active mutants” in claim 1 defined by claim 4.<sup>63</sup>

#### **V. All Challenged Claims Are Unpatentable Under § 112 and None Are Entitled to Benefit to Any Pre-March 13, 2013 Application**

Claims 1-40 are unpatentable because each lacks written description in and was not enabled by the common disclosure of the '652 Patent and the '731 Application in 2011.

Per § IV.D.1, the claim language defines enormous genera: between  $10^{59}$  and  $10^{112}$  distinct polypeptides. Their real-world scope is absurd—to practice the claims' full scope requires a skilled artisan to make-and-test at least  $\sim 10^{59}$  mutants. Simply producing one molecule of each mutant—required to know if each is active

---

<sup>62</sup> EX1001, 135:9-20; *see also id.* at 42:51-58.

<sup>63</sup> EX1003, ¶¶ 136-137.

or inactive or exhibits increased stability—which for each genera’s many multi-substituted mutants would consume an aggregate mass ( $\sim 3.93 \times 10^{37}$  kg) that exceeds the mass of the Earth ( $\sim 6 \times 10^{24}$  kg).<sup>64</sup> Testing every polypeptide within the claims’ scope in search of “active mutants” is impossible—literally.

Relative to that broad scope, the ’652 Patent and the ’731 Application provide only a meager disclosure: *singly*-modified PH20 polypeptides and a prophetic, make-and-test research plan to discover multiply-modified ones. It nowhere demonstrates possession of the vast remainder of multiply-modified polypeptides in the claims’ scope, nor does it enable a skilled artisan to practice that full-range of mutant polypeptides without undue experimentation.

#### **A. All Claims Lack Written Description**

The written description analysis focuses on the four corners of the patent disclosure.<sup>65</sup> “To fulfill the written description requirement, a patent owner must convey with reasonable clarity to those skilled in the art that, as of the filing date sought, he or she was in possession of the invention, and demonstrate that by

---

<sup>64</sup> EX1003, ¶¶ 126, 199; *see also, e.g.*, EX1039, 136-37 (10<sup>390</sup> forms of a polypeptide possible from 300 residue sequence).

<sup>65</sup> *Ariad Pharms., Inc. v. Eli Lilly & Co.*, 598 F.3d 1336, 1351 (Fed. Cir. 2010) (*en banc*).

disclosure in the specification of the patent.”<sup>66</sup> If the claims define a genus, the written description must “show that one has truly invented a genus ...,” “[o]therwise, one has only a research plan, leaving it to others to explore the unknown contours of the claimed genus.”<sup>67</sup>

“[A] genus can be sufficiently disclosed by either a representative number of species falling within the scope of the genus or structural features common to the members of the genus so that one of skill in the art can visualize or recognize the members of the genus.”<sup>68</sup> “One factor in considering [written description] is how large a genus is involved and what species of the genus are described in the patent ... [I]f the disclosed species only abide in a corner of the genus, one has not described the genus sufficiently to show that the inventor invented, or had possession, of the genus.”<sup>69</sup>

---

<sup>66</sup> *Idenix Pharm., LLC v. Gilead Scis., Inc.*, 941 F.3d 1149, 1163 (Fed. Cir. 2019) (internal quotation marks omitted).

<sup>67</sup> *AbbVie Deutschland GmbH & Co., KG v. Janssen Biotech, Inc.*, 759 F.3d 1285, 1300 (Fed. Cir. 2014).

<sup>68</sup> *Idenix*, 941 F.3d at 1164.

<sup>69</sup> *AbbVie*, 759 F.3d at 1299-1300.

A disclosure that fails to “provide sufficient blaze marks to direct a POSA to the specific subset” of a genus with the claimed function or characteristic does not satisfy § 112(a).<sup>70</sup> And “merely drawing a fence around the outer limits of a purported genus” is insufficient.<sup>71</sup> Instead, “the specification must demonstrate that the applicant has made a generic invention that achieves the claimed result and do so by showing that the applicant has invented species sufficient to support a claim to the functionally-defined genus.”<sup>72</sup>

Three cases are especially probative. First, in *AbbVie*, the Federal Circuit found a disclosure of 300 examples of IL-12 antibodies to not be representative of a functionally defined antibody genus:

Although the number of the described species appears high quantitatively, the described species are all of the similar type and do not qualitatively represent other types of antibodies encompassed by the genus.<sup>73</sup>

---

<sup>70</sup> *Idenix*, 941 F.3d at 1164.

<sup>71</sup> *Ariad*, 598 F.3d at 1350-54.

<sup>72</sup> *Id.* at 1349.

<sup>73</sup> *AbbVie*, 59 F.3d at 1300-1301.

It also criticized the prophetic description as being “only a research plan, leaving it to others to explore the unknown contours of the claimed genus” and a “trial and error approach.”<sup>74</sup>

Second, *Idenix* addressed method of treatment claims using a broad genera of compounds defined by formulas: “eighteen position-by-position formulas describing ‘principal embodiments’ of compounds that may treat HCV,” each with “more than a dozen options” at each position (totaling “more than 7,000 unique configurations”).<sup>75</sup> The court criticized the specification’s failure to indicate which of the thousands of compounds would be effective, and found that “provid[ing] lists or examples of supposedly effective nucleosides,” without “explain[ing] what makes them effective, or why” deprives a skilled artisan “of any meaningful guidance into what compounds beyond the examples and formulas, if any, would provide the same result” because they “fail[] to provide sufficient blaze marks to direct a POSA to the specific subset of 2’-methyl-up nucleosides that are effective in treating HCV.”<sup>76</sup>

---

<sup>74</sup> *Id.*

<sup>75</sup> *Idenix*, 941 F.3d at 1158-64.

<sup>76</sup> *Id.* at 1164.

Finally, the Board in *Boehringer Ingelheim Animal Health USA Inc. v. Kan. State Univ. Research Found.*, PGR2020-00076, Paper 42, 6 (P.T.A.B. Jan. 31, 2022) considered claims employing “90% sequence homology” language that captured “broad genus of amino acid sequence homologues” but which (like here) imposed no restrictions where particular replacements could be made, thereby causing the claim “to cover, at minimum, thousands of amino acid sequences.”<sup>77</sup> The Board found fatal the specification’s failure to “explain what, if any, structural features exist (*e.g.*, remain) in sequences that vary by as much as 10% that allow them to retain the antigenic characteristics referenced in the Specification” and noted the homology limitation “serves to merely draw a fence around the outer limits of a purported genus [which] is not an adequate substitute for describing a variety of materials constituting the genus” for purposes of section 112(a).<sup>78</sup>

The deficiencies of the present claims dwarf those in these three cases. They define much larger, much less predictable, and much more diverse genera, and the common disclosure is far more limited. Because the common disclosure neither discloses a representative number of species, nor identifies sufficient structural

---

<sup>77</sup> *Boehringer*, at 16. The claims included methods of using proteins. *Id.* at 6.

<sup>78</sup> *Id.* at 35-36.

features common to the members of each claimed genus, it fails to demonstrate possession of the genera defined by the claims of the '652 Patent.

**1. Claims 1-2, 6-15, and 24-25 Lack Written Description**

*a) The Claims Capture Massive and Diverse Genera of Enzymatically Active PH20 Polypeptides*

The genera of modified PH20 polypeptides of claims 1-2, 6-15, and 24-25 are not only immense, but structurally and functionally diverse. They capture PH20 mutants with 2, 3, or more substitutions up to a number set by the sequence identity boundary (*i.e.*, 21 for the narrowest claims (*e.g.* claims 24 and 25) to 42 for the broadest (claim 1)). The optional substitutions can be anywhere in the sequence (*i.e.*, clustered in a narrow region, spaced apart in groups, or spread randomly throughout the sequence), to any of 19 other amino acids, and arranged in any manner.<sup>79</sup> They thus capture a mutant with 5 substituted hydrophobic residues clustered in a small region, as well as one with up to 42 substitutions that mix polar, charged, aliphatic, and aromatic amino acids together in any manner.<sup>80</sup>

Each claim also encompasses substitutions within C-terminally truncated forms of PH20 of varying lengths. Claim 1 does this explicitly, specifying 37 alternative sequences that terminate at positions 430 to 474. The claims' sequence

---

<sup>79</sup> EX1003, ¶ 122; EX1001, 60:57-64, 47:46-50, 47:59-61, 42:6-12.

<sup>80</sup> EX1003, ¶¶ 122-23.

identity language also captures PH20 polypeptides that terminate at positions before 430. For example, claims referencing SEQ ID NO: 32 that allow between 21 and 42 changes (with any mixture of deletions and substitutions) capture a PH20 terminating at position 416 or below. But removing so many residues from the C-terminus of PH20 can render it inactive, and the disclosure does not describe or suggest that position 320 substitutions would restore activity.<sup>81</sup> The claims, however, capture such polypeptides.

*b) The Claims Capture Modified PH20 Polypeptides the Common Disclosure Says to Avoid or Not Make*

The claims' unconstrained sequence identity language captures three categories of PH20 mutants a skilled artisan would understand the disclosure to be saying to avoid. Each raises unique questions relative to the remainder of the genus and are thus distinct "sub-genera" of PH20 mutants that are not representative of other "sub-genera" within the claimed genera. But instead of providing guidance that navigates this confusing landscape, the patent simply instructs the skilled artisan "to generate a modified PH20 polypeptide containing any one or more of the described mutation, and test each for a property or activity

---

<sup>81</sup> EX1003, ¶¶ 167-70.

as described herein.”<sup>82</sup> The common disclosure thus does not describe any of the polypeptides within these sub-genera being claimed.

(i) Multiply-Modified PH20 Mutants to Not Make

The common disclosure affirmatively addresses only six, specific modified PH20 polypeptides with more than one identified (*i.e.*, position and amino acid) substitution, but its guidance is to ***not make those polypeptides***:

[W]here the modified PH20 polypeptide contains only two amino acid replacements, the amino acid replacements are ***not*** P13A/L464W, N47A/N131A, N47A/N219A, N131A/N219A or N333A/N358A. In a further example, where the modified PH20 polypeptide contains only three amino acid replacements, the amino acid replacements are ***not*** N47A/N131A/N219A.<sup>83</sup>

No explanation is provided why these particular combinations of replacements should be avoided, nor is any data from testing their activity or other characteristics provided.<sup>84</sup> The substitutions are not included in Tables 5 and 10

---

<sup>82</sup> EX1001, 78:34-38; EX1003, ¶ 203.

<sup>83</sup> EX1001, 77:45-57 (emphases added).

<sup>84</sup> EX1003, ¶¶ 149-50; EX1001, 49:33-38.

(i.e., “inactive mutants”) and N219A PH20<sub>1-447</sub> showed increased activity (129%).<sup>85</sup> Nothing in the claim language excludes these combinations.

(ii) Substitutions to Avoid in Active Mutants

The common disclosure indicates that active mutant modified PH20 polypeptides should not incorporate amino acid substitutions that rendered PH20<sub>1-447</sub> inactive, stating:

***To retain hyaluronidase activity***, modifications typically ***are not made*** at those positions that are less tolerant to change or required for hyaluronidase activity.<sup>86</sup>

It identifies these changes as: (i) any substitution at 96 different positions in the PH20 sequence, and (ii) 313 specific amino acid substitutions listed in Tables 5 and 10 that are made at other positions.<sup>87</sup> It does not limit this observation to single-replacement PH20<sub>1-447</sub> mutants, or suggest that any of these substitutions that render PH20<sub>1-447</sub> inactive should be included in enzymatically active, multiply-modified PH20 polypeptides (much less identify specific combinations including them).<sup>88</sup> Instead, by stating that the substitutions listed in Tables 5 and 10 should

---

<sup>85</sup> EX1001, 245 (Table 9).

<sup>86</sup> EX1001, 80:13-15 (emphases added).

<sup>87</sup> EX1001, 80:15-55 .

<sup>88</sup> EX1003, ¶¶ 154, 164-65, 172.

not be included in enzymatically active multiply-modified PH20 polypeptides, it clearly conveys to the skilled artisan that the *claimed* enzymatically active multiply-modified PH20 polypeptides do not and should not contain them.<sup>89</sup> The sequence identity claim parameters, however, capture such mutants.

(iii) PH20 with Significant C-terminal Truncations Can Lose Activity

The common disclosure does not describe and provides no guidance concerning “active mutant” PH20 polypeptides having fewer than 447 residues, particularly multiply-modified PH20 mutants terminating significantly before that position.<sup>90</sup>

The common disclosure and the prior art do report that wild-type PH20 polypeptides terminating at or below position 442 have *significantly reduced or no* hyaluronidase activity. For example, Patentee’s ’429 Patent reported that PH20 mutants terminating below position 432 residues lacked hyaluronidase activity, while those terminating between positions 432 and 448 had widely varying activities (below):<sup>91</sup>

---

<sup>89</sup> EX1003, ¶¶ 151-54, 165; EX1001, 80:13-55, 70:46-56.

<sup>90</sup> EX1003, ¶¶ 97, 100, 170-72; EX1001, 74:9-15.

<sup>91</sup> EX1005, 87:52-88:24 (PH20<sub>1-442</sub> activity “decreased to approximately 10%”); EX1013, Figure 2, 430-32 (“[l]ess than 10% activity was recovered when

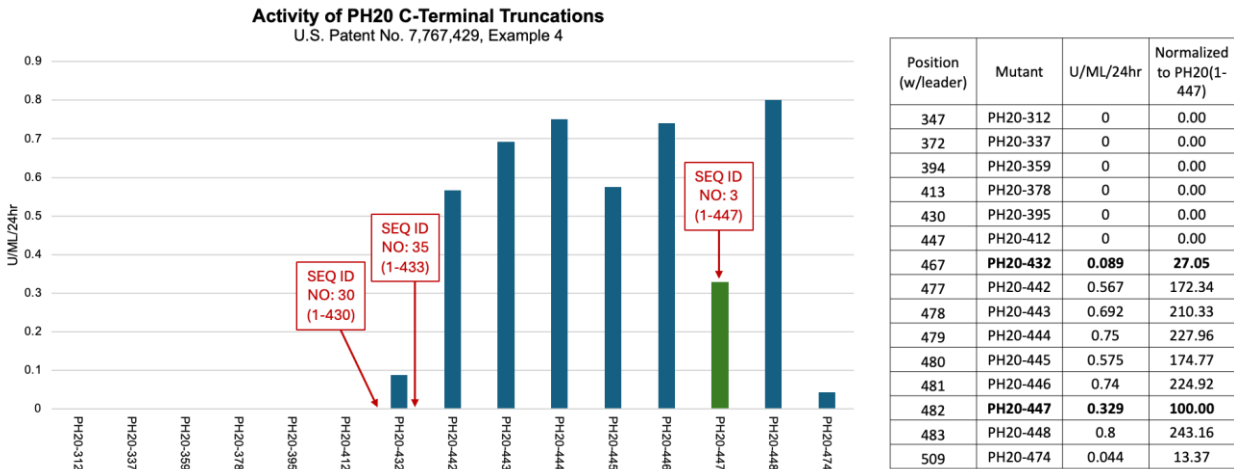

Patentee's '429 Patent also reported that "a very narrow range spanning ... [437-447] ... defined the minimally active domain" of human PH20, and elsewhere observed this "minimally active" human PH20 domain contains at least residues 1-429.<sup>92</sup>

The common disclosure reiterates these findings, stating that PH20 polypeptides must extend to at least position 429 to exhibit hyaluronidase activity:

A mature PH20 polypeptide ... containing a contiguous sequence of amino acids having a C-terminal amino acid residue corresponding to amino acid residue **464** of SEQ ID

---

constructs terminated after amino acid 467 [432] or when using the full-length PH20 cDNA"); EX1003, ¶ 94.

<sup>92</sup> EX1005, 6:65-7:7 ("... sHASEGP from amino acids 36 to Cys 464 [429] ... comprise the minimally active human sHASEGP hyaluronidase domain"); EX1003, ¶ 93.

NO: 6 [position **429** without signal] ... *is the minimal sequence required for hyaluronidase activity*.<sup>93</sup>

In 2007, Chao reported that the C-terminal region of human hyaluronidases contains a unique domain (“Hyal-EGF”) linked to a characteristic pattern of sequences.<sup>94</sup> In PH20, the Hyal-EGF domain runs from positions 337-409.<sup>95</sup> In 2009, Zhang showed the Hyal-EGF domain was necessary for hyaluronidase activity.<sup>96</sup>

The C-terminus of PH20 is illustrated below, showing (i) the positions where SEQ ID NOS: **3** (447), **32** (430) and **35** (433) terminate, (ii) the “minimally active domain” at 437-447, and (iii) residues below position 429.<sup>97</sup> Positions resulting from deletion of 21 or 16 residues from SEQ ID NOS: 32 and 35 end before position 429.

---

<sup>93</sup> EX1001, 69:66-70:8 (emphases added); *also* EX1003, ¶¶ 96, 155.

<sup>94</sup> EX1006, 6912; EX1003, ¶¶ 84, 87-88.

<sup>95</sup> EX1004, ¶¶ 97-99; EX1003, ¶ 95.

<sup>96</sup> EX1010, 9438; EX1003, ¶ 89.

<sup>97</sup> EX1003, ¶ 156.

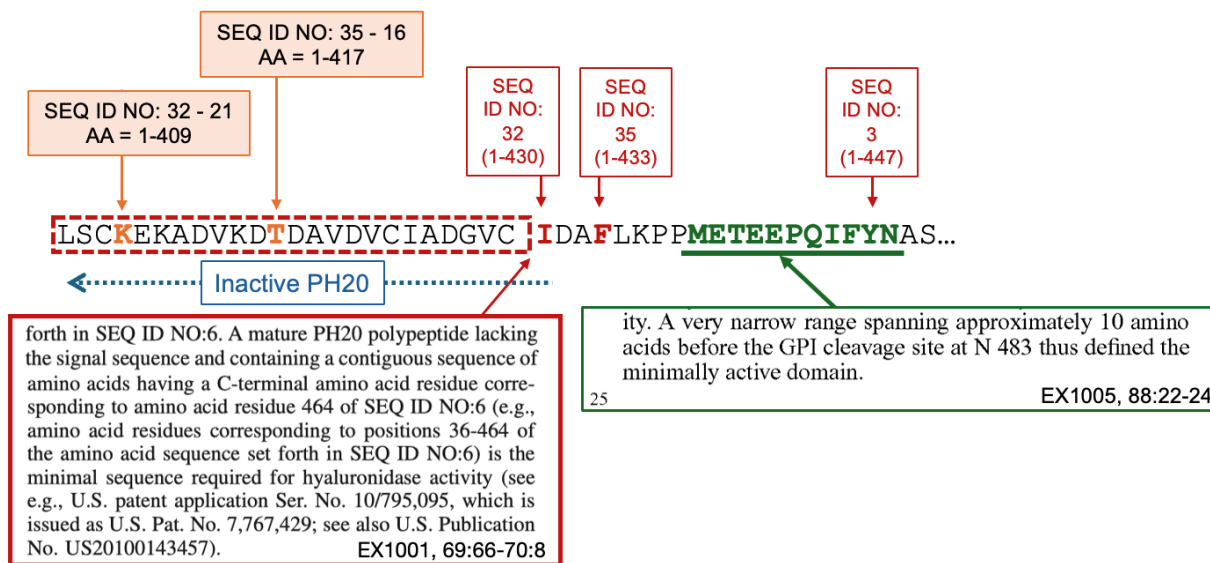

Consequently, a skilled artisan in 2011 would have believed that PH20 polypeptides that terminate before position 430 would be inactive (*e.g.*, at position 419, below).<sup>98</sup>

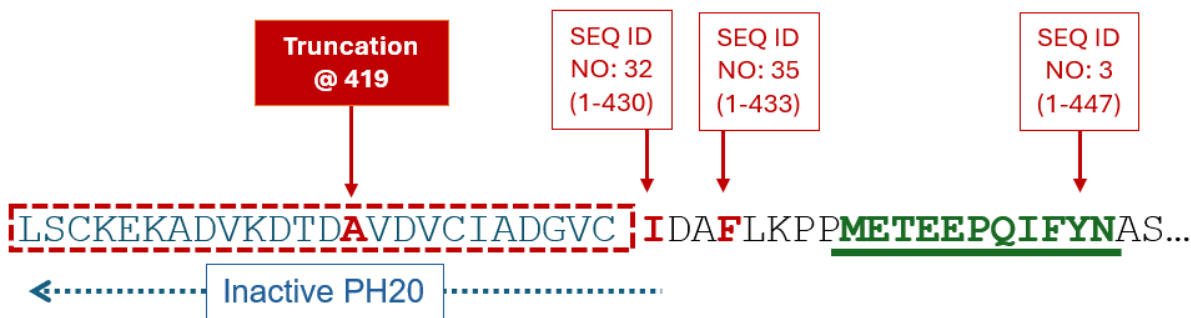

The common disclosure provides no examples of (or guidance concerning) PH20 mutants truncated below position 447 with one or more substitutions and that are enzymatically active. It thus ignores the uncertainty existing in 2011 about

<sup>98</sup> EX1003, ¶¶ 95-96, 168-169.

PH20 truncation mutants that terminate between positions 419 to 433.<sup>99</sup> The claims nonetheless capture modified PH20 polypeptides with truncations down to and beyond position 419.<sup>100</sup>

c) *Empirical Test Results of Single-Replacement Modified PH20 Polypeptides Do Not Identify Multiply-Modified Enzymatically Active PH20 Polypeptides*

The empirical results in the common disclosure provide no predictive guidance to a skilled artisan about the structural features of multiply-modified PH20 polypeptides within the claimed genera that are enzymatically active.

(i) The Data Concerning Single-Replacements Is Not Probative of Multiple-Replacement Mutants

The common disclosure reports results from testing a portion of a randomly generated library of ~6,743 single-replacement PH20<sub>1-447</sub> polypeptides.<sup>101</sup> These mutants were generated via a mutagenesis process which substituted one of ~15 amino acids into random positions in PH20<sub>1-447</sub> “such that each member contained a single amino change.”<sup>102</sup> Approximately 5,917 were tested, while ~846 were

---

<sup>99</sup> EX1003, ¶¶ 95-96, 98, 100.

<sup>100</sup> EX1003, ¶¶ 167-69.

<sup>101</sup> EX1001, 127:45-56, 194:44-46, 194:24-30.

<sup>102</sup> EX1001, 194:24-33.

uncharacterized.<sup>103</sup> More than half (~57%) of these mutants were classified as “inactive mutants,” while ~30% (1335) were reported to have less activity than unmodified PH20<sub>1-447</sub> (20%-100%).<sup>104</sup> In other words, ~87% of the single-replacement PH20<sub>1-447</sub> polypeptides had *less* activity than unmodified PH20<sub>1-447</sub>.<sup>105</sup>

Activity vs. Unmodified PH20	Number	% of Tested (5916)
Active Mutants (Table 9)		
>120%	532	9.0%
100%-120%	267	4.5%
40%-100%	1577	26.7%
Inactive Mutants (Table 9)		
<40%	160	2.7%
Inactive Mutants (Table 10)		
Table 10 ‘inactive mutants’	3,380	57.1%

<sup>103</sup> EX1003, ¶¶ 106-107. Inconsistent numbers and classifications of mutants are not explained: (i) Table 3 lists 2,516 single-replacement PH20<sub>1-447</sub> mutants as “active mutants,” but Table 9 identifies only 2,376 mutants that exhibit >40% hyaluronidase activity; (ii) Tables 5 and 10 list 3,368 and 3,380 PH20<sub>1-447</sub> “inactive mutants,” respectively.

<sup>104</sup> EX1003, ¶ 108.

<sup>105</sup> *Id.*

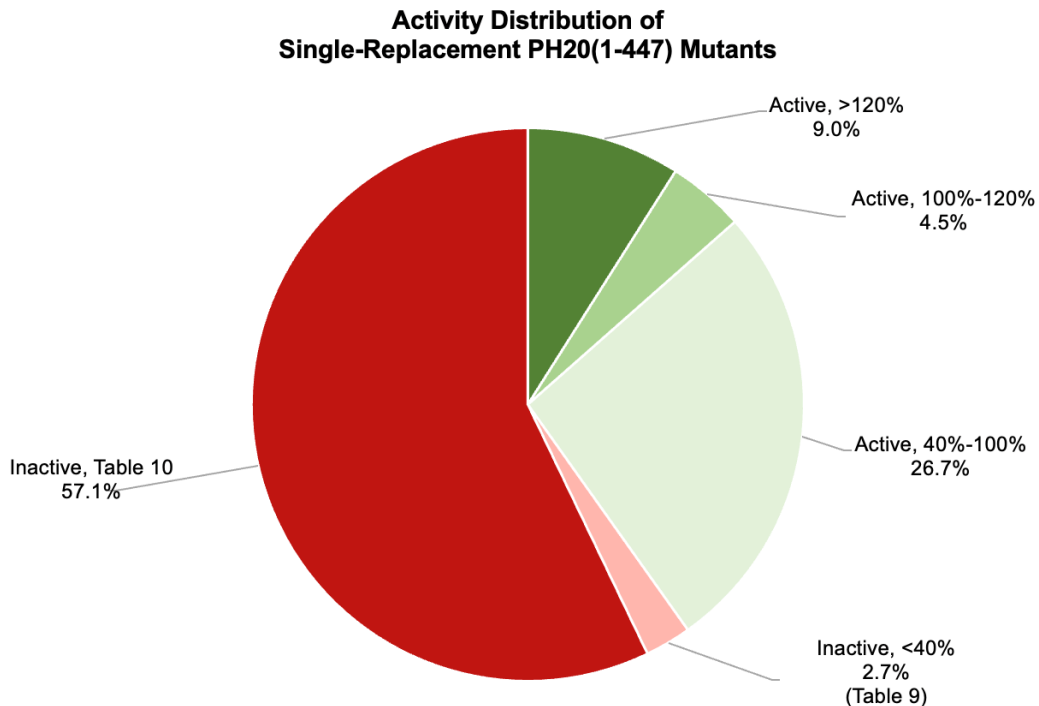

The measured activity of single-replacement PH20<sub>1-447</sub> mutants shows no trends or correlations even for single-replacement PH20<sub>1-447</sub> polypeptides.<sup>106</sup> Instead, numerous examples show that even introducing different amino acids at the same position in PH20<sub>1-447</sub> resulted in (i) increased activity, (ii) decreased activity, or (iii) inactive mutants (below).<sup>107</sup>

---

<sup>106</sup> EX1003, ¶¶ 109, 145-46.

<sup>107</sup> Data from Tables 3, 5, 9, 10.

<b>Position</b>	<b>Inactive</b>	<b>Decreased Activity</b>	<b>Increased Activity</b>
<b>008</b>	P	L, M	I
<b>067</b>	R	L, Y	V
<b>092</b>	H	M, T	C, L, V
<b>165</b>	C	A, R, Y	D, F, N, S, V, W
<b>426</b>	K, S	E, G, N, Q, Y	P

The data on activities of tested single-replacement PH20<sub>1-447</sub> mutants is not analyzed or explained in the common disclosure—it is simply presented. There is no attempt to extrapolate its results to any combinations of substitutions in PH20 polypeptides, or to assess the impact of a single substitution on the protein's structure.<sup>108</sup> The quality of the data is also questionable: no control values or statistical assessments are provided.<sup>109</sup> All the data shows is that most of the tested single-substitution mutants impaired PH20's activity.<sup>110</sup>

The results from single substitutions provide no insights into PH20 polypeptides with multiple concurrent mutations, which together can cause complex and unpredictable effects on a protein's structure and resulting

---

<sup>108</sup> EX1003, ¶ 142.

<sup>109</sup> EX1003, ¶ 109.

<sup>110</sup> EX1003, ¶ 141.

function.<sup>111</sup> The patent's empirical test results thus provide no guidance to a skilled artisan about which of the many possible PH20 mutants with different sets of 2-42 substitutions will be enzymatically active.<sup>112</sup>

(ii) Purported Stability Data Is Not Reliable or Probative

The common disclosure reports results in Tables 11 and 12 from two runs of “stability” testing of ~409 single-replacement PH20<sub>1-447</sub> polypeptides.<sup>113</sup> Table 11 reports the hyaluronidase activity of single-replacement PH20<sub>1-447</sub> mutants tested at 4° C and 37° C, and in the presence of a “phenolic preservative” (m-cresol),<sup>114</sup> while Table 12 compares relative activities under pairs of these conditions.<sup>115</sup>

The data in Tables 11 and 12 provides no meaningful insights.<sup>116</sup> For example, unsurprisingly, single-replacement PH20<sub>1-447</sub> polypeptides showed higher activity at 37° C than at 4° C, given that PH20 exists at the former temperature in

---

<sup>111</sup> EX1003, ¶¶ 142, 145.

<sup>112</sup> EX1003, ¶¶ 143, 146.

<sup>113</sup> EX1001, 267:63-269:45.

<sup>114</sup> EX1001, 269:46-276:20 (Table 11).

<sup>115</sup> EX1001, 276:21-287:29 (Table 12).

<sup>116</sup> EX1003, ¶ 76.

humans.<sup>117</sup> And all that testing with m-cresol showed was that only a few mutants were able to resist its effects, with no explanation why.<sup>118</sup>

With one exception, there is no evidence the measured activity data was attributable to improved stability of PH20.<sup>119</sup> More directly, the common disclosure does not identify which *combinations* of substitutions improve stability.<sup>120</sup> It thus provides no probative insight regarding multiply-modified PH20 polypeptides with increased stability.<sup>121</sup>

The data is also largely meaningless, as many of their values fall within the range of activity observed for the positive control.<sup>122</sup> As the charts and table below show, the activity of unmodified PH20<sub>1-447</sub> varied by 97% and 87% in two rounds of testing.<sup>123</sup>

---

<sup>117</sup> EX1003, ¶ 73; EX1001, 170:62-171:4.

<sup>118</sup> EX1003, ¶ 69.

<sup>119</sup> EX1003, ¶ 69.

<sup>120</sup> EX1003, ¶¶ 75-76.

<sup>121</sup> *Id.*

<sup>122</sup> EX1003, ¶ 71; EX1001, 287 (Table 12).

<sup>123</sup> EX1003, ¶ 71, Appendix A-7, A-8.

Positive Control ("PC") (OHO)	Duplicate #1			Duplicate #2		
	% Activity at 37°C/4°C	% Activity at 37°C+m-cresol / 37°C	% Activity at 37°C + mcr/4°C	% Activity at 37°C/4°C	% Activity at 37°C+m-cresol / 37°C	% Activity at 37°C+mcr/4 °C
PC1	94.998	5.230	4.970	96.871	8.456	8.190
PC2	105.798	4.480	4.740	108.066	5.246	5.670
PC3	100.000	3.330	3.330	82.778	3.759	4.590
PC4	94.762	19.070	18.070	109.539	16.529	18.110
PC5	142.024	4.480	6.360	130.947	5.595	7.330
PC6	45.115	20.770	9.370	68.017	11.035	7.510
PC7	53.324	21.950	11.710	74.253	9.960	7.400
PC8	59.581	25.240	15.040	75.872	16.231	12.310
PC9	91.844	19.050	17.500	80.371	13.977	11.230
PC10	93.828	13.470	12.630	96.630	19.454	18.800
PC11	57.773	17.040	9.850	83.536	17.573	14.680
PC12	100.000	18.560	18.560	148.226	16.239	24.070
PC13	74.325	18.290	13.600	61.119	9.286	5.680
PC14	98.132	8.480	8.320	87.677	10.006	8.770
PC15	93.817	9.620	9.020	102.223	9.745	9.960
PC16	96.922	8.560	8.300	87.993	9.064	7.980
PC17	96.648	9.910	9.580	86.891	9.938	8.630

KEY
Coloration of Percent (%) Activity Values
n/a
>120
between 100 and 120
between 80 and 100
between 40 and 80
between 20 and 40
between 10 and 20
between 0 and < 10

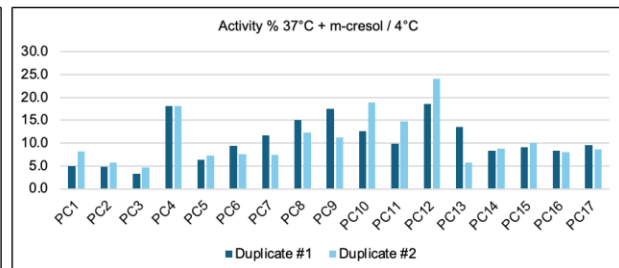
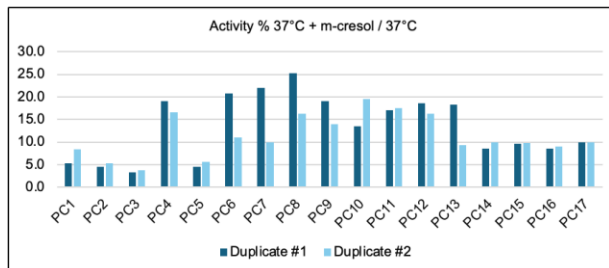
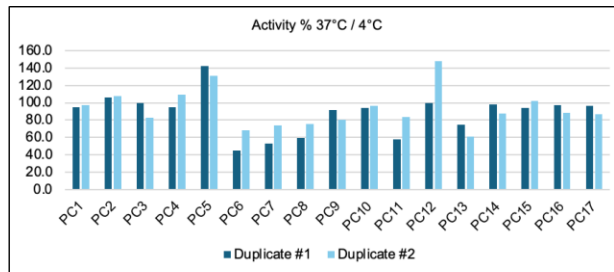

	Duplicate #1			Duplicate #2		
	% Activity at 37°C/4°C	% Activity at 37°C + m-cresol	% Activity at 37°C + mcr/4°C	% Activity at 37°C/4°C	% Activity at 37°C+m-cresol	% Activity at 37°C+mcr/4°C
High	142.02	25.24	18.56	148.23	19.45	24.07
Low	45.12	3.33	3.33	61.12	3.76	4.59
Range	96.91	21.91	15.23	87.11	15.70	19.48
Average	88.17	13.38	10.64	93.00	11.30	10.64
Mean	94.76	13.47	9.58	87.68	9.96	8.63

As Dr. Hecht observes, this “significant variation raises serious doubts about how probative or instructive the values of individual tested mutants that fall within the range of variability observed for the control can possibly be.”<sup>124</sup> The data not only fails to identify specific combinations of substitutions that yield PH20 mutants with increased resistance to or stability in denaturing conditions, it is unreliable.

*d) The Common Disclosure’s Research Plan Does Not Identify Multiply-Mutated Enzymatically Active PH20 Polypeptides*

The common disclosure does not describe any multiply-modified PH20 polypeptides that are “active mutants.” Instead, it simply presents *the idea* of multiply-modified PH20 polypeptides. First, it observes that “[a] modified PH20 polypeptide can have up to 150 amino acid replacements,” “[t]ypically” contains between 1 and 50 amino acid replacements and “can include any one or more other

<sup>124</sup> EX1003, ¶¶ 70-72; see also EX1001, 287:35-45 (positive control also varied).

modifications, in addition to at least one amino acid replacement as described herein.”<sup>125</sup> It also contends a modified PH20 polypeptide with “a sequence of amino acids that exhibits” between 68% and 99% sequence identity with any of unmodified SEQ ID NOS: 74-855 “*can* exhibit altered, such as improved or increased, properties or activities compared to the corresponding PH20 polypeptide not containing the amino acid modification (*e.g.*, amino acid replacement).”<sup>126</sup>

None of these statements identify *any* actual multiply-modified PH20 polypeptides (*i.e.*, particular sets of specific amino acid substitutions), much less provide results from testing any. They simply draw boundaries around a theoretical and immense genus of modified PH20 polypeptides.

The common disclosure also describes no methods that produce any specific multiply-modified, enzymatically active PH20 polypeptides. What it provides instead is a prophetic research plan requiring “iterative” make-and-test experiments that *might discover* multiply-modified enzymatically active PH20 polypeptides:

The method provided herein [] is *iterative*. In one example, after the method is performed, any modified hyaluronan-degrading enzymes identified as exhibiting stability ... *can be modified or further modified* to increase or optimize the

---

<sup>125</sup> EX1001, 48:46-56.

<sup>126</sup> EX1001, 97:1-15 (emphasis added).

stability. A secondary library *can be* created by introducing additional modifications in a first identified modified hyaluronan-degrading enzyme. ... The secondary library *can be* tested using the assays and methods described herein.<sup>127</sup>

This prophetic research plan is effectively meaningless—it does not indicate that any active mutant multiply-modified PH20 polypeptides will be found, much less identify *which* multiply-modified PH20 polypeptides are active mutants.<sup>128</sup>

An alternative focus is then proposed: mutations can be “targeted near” “critical residues” which supposedly “can be identified because, when mutated, a normal activity of the protein is ablated or reduced.”<sup>129</sup> But Tables 5 and 10 show that at least one substitution at each of 405 positions between positions 1 and 444 of PH20<sub>1-447</sub> resulted in an inactive mutant.<sup>130</sup> In other words, the common disclosure’s guidance is to target locations “near” ~90% of the amino acids in

---

<sup>127</sup> EX1001, 135:8-20 (emphases added); *see also id.* at 42:51-58, 128:24-29; EX1003, ¶¶ 182-186.

<sup>128</sup> EX1003, ¶¶ 182, 193-94, 200; EX1001, 44:3-5; *see generally id.*, 127:45-128:23, 128:32-130:7, 130:34-135:7.

<sup>129</sup> EX1001, 135:21-46; EX1003, ¶¶ 187-88.

<sup>130</sup> EX1003, ¶ 189, Appendix A-3.

PH20<sub>1-447</sub>, which is no different than targeting every residue in the protein.<sup>131</sup> It is, like the first proposed “iterative” process, meaningless.

These prophetic research plans, based entirely on unfocused, iterative “make-and-test” experiments, provide no direction to the skilled artisan about which of the trillions and trillions of possible multiply-modified PH20 polypeptides are enzymatically active.<sup>132</sup> Instead, they require the skilled artisan to repeat the cycle of mutagenesis iteratively, screening and selecting until 10<sup>59</sup> to 10<sup>112</sup> modified PH20 polypeptides are produced and screened for activity.<sup>133</sup> That in no way demonstrates possession of the claimed genus.

The specification also incorrectly portrays the experimental readout—hyaluronidase activity—as a measure of “stability.”<sup>134</sup> As Dr. Hecht explains, to assess a protein’s stability directly one performs experiments that measure the energy associated with the protein’s transition between its folded and unfolded

---

<sup>131</sup> EX1003, ¶ 189.

<sup>132</sup> EX1003, ¶ 200.

<sup>133</sup> EX1003, ¶¶ 184-86, 197-99; EX1001, 130:15-20, 130:8-32, 133:26-30, 133:41-46, 133:63-134:10.

<sup>134</sup> EX1003, ¶¶ 67, 69, 188.

states.<sup>135</sup> Activity may or may not be influenced by stability but is not itself a measure of stability.<sup>136</sup>

*e) The Common Disclosure Does Not Identify a Structure-Function Relationship for Multiply-Modified, Enzymatically Active PH20 Polypeptides*

The common disclosure does not identify the structural significance of any of the ~2,500 mutations that yielded single residue “active mutant” PH20<sub>1-447</sub> polypeptides (or the ~3,400 inactive mutants). For example, it does not identify the effect of any replacement on any domain structure, any structural motif(s) or even the local secondary structure at the site of the substitution in the PH20 polypeptide, nor does it identify how any such (possible) structural change(s) is/are responsible for the measured change in hyaluronidase activity.<sup>137</sup> Instead, it simply lists single replacements to random amino acids at random positions that were classified as “active mutants” by a hyaluronidase assay; nothing is said about the effects (if any) of substitutions on the protein’s structure.<sup>138</sup>

---

<sup>135</sup> EX1003, ¶¶ 63-66.

<sup>136</sup> EX1003, ¶ 67.

<sup>137</sup> EX1003, ¶¶ 142-43, 154.

<sup>138</sup> EX1001, 227:5-33; EX1003, ¶¶ 142-43, 145.

The common disclosure also does not identify any *sets* of specific amino acid replacements that correlate to structural domains or motifs that positively or negatively influence hyaluronidase activity, much less *predictably* increase activity to defined thresholds.<sup>139</sup> Again, it simply reports activity data from testing randomly generated *single*-replacement PH20<sub>1-447</sub> mutants.

The common disclosure's empirically identified examples of "active mutant" single-replacement PH20<sub>1-447</sub> mutants also do not *by themselves* identify any "structure-function" relationship between "active mutants" and the set of single-replacement modified PH20<sub>1-447</sub> polypeptides.<sup>140</sup> They certainly do not do so for the much larger genus of modified PH20 polypeptides of varying lengths and between 2 and 42 substitutions.<sup>141</sup>

Critically, the common disclosure *does not even contend* that a particular amino acid replacement at a particular position (*e.g.*, 320) that makes a PH20<sub>1-447</sub> an "active mutant" will make any other modified PH20 polypeptide with that same amino acid replacement (plus between 1 and 41 additional replacements or

---

<sup>139</sup> EX1003, ¶¶ 55, 145-46.

<sup>140</sup> EX1003, ¶¶ 61, 146, 160, 162.

<sup>141</sup> EX1003, ¶ 160.

truncations) an “active mutant.”<sup>142</sup> Such an assertion would have no scientific credibility—the activity of a protein such as PH20 is dictated by its overall structure, which can be influenced unpredictably by different combinations of changes to its amino acid sequence.<sup>143</sup> Thus, even the inventors did not view their compilation of test results as identifying a structure-function correlation for multiply-modified PH20 polypeptides.

The common disclosure, thus, does not identify to a skilled artisan *any* structural features shared by the many, diverse “active mutant” modified PH20 polypeptides within the scope of the claims,<sup>144</sup> and thus cannot satisfy the written description requirement of § 112(a) as a disclosure that links a functional property to a particular structure *shared* by the members of the genus.

---

<sup>142</sup> EX1003, ¶¶ 171, 201-202.

<sup>143</sup> EX1003, ¶¶ 56-57.

<sup>144</sup> EX1003, ¶ 160.

*f) The Common Disclosure Does Not Describe a Representative Number of Multiply-Modified Enzymatically Active PH20 Polypeptides*

The ~2,500 active mutant single-replacement PH20<sub>1-447</sub> polypeptides in the disclosure are not representative of the claimed genera or the various sub-genera within the claims.<sup>145</sup>

First, these single-replacement PH20<sub>1-447</sub> examples are not representative of the trillions and trillions of PH20<sub>1-447</sub> polypeptides with between **2 and 42** *substitutions* at any of hundreds of positions within the protein.<sup>146</sup> The latter group of proteins is structurally distinct from single replacement PH20 polypeptides, both as to their sequences and as to the various secondary structures and structural motifs within the folded proteins that result when multiple amino acid substitutions are incorporated and from the distinct interactions they can cause with neighboring residues.<sup>147</sup> The effects of numerous substitutions on the PH20 protein's various secondary structures and structural motifs are not described or discussed in the common disclosure, and the magnitude of structural changes resulting from the

---

<sup>145</sup> EX1003, ¶¶ 61, 146, 158, 162.

<sup>146</sup> See § IV.D.1; EX1003, ¶¶ 61, 146, 162.

<sup>147</sup> EX1003, ¶¶ 55-56, 58, 60, 159, 162.

concurrent substitutions encompassed by the claims was unknowable in 2011.<sup>148</sup>

The overall activity of a protein with multiple substitutions also will not be due to one amino acid, but to the unique structure of each protein that reflects *the totality* of effects of those many substitutions.<sup>149</sup>

More specifically, introducing a first amino acid substitution often affects the neighbors of that original/replaced amino acid by, for example, (i) introducing a stabilizing interaction, (ii) removing a stabilizing interaction, and/or (iii) introducing a conflicting interaction (*e.g.*, adverse charge or hydrophobicity interactions).<sup>150</sup> Introducing a second substitution in that region may reverse those interactions (or not) with each neighboring residue, and a third substitution may do the same, with up to 21 rounds permitted by even the narrowest claims, each potentially impacting each interaction.<sup>151</sup> The data associated with a single amino acid substitution thus cannot be representative of the properties of any of these downstream, multiply-substituted mutants, which will have an unknowable

---

<sup>148</sup> EX1003, ¶¶ 160-61, 239.

<sup>149</sup> EX1003, ¶¶ 61, 144.

<sup>150</sup> EX1003, ¶¶ 56-58.

<sup>151</sup> EX1003, ¶¶ 58-60, 145.

combination of substitutions that each uniquely impact the properties of the mutated protein.<sup>152</sup>

Enzymatically active single-replacement PH20<sub>1-447</sub> polypeptides also are not representative multiply modified PH20 polypeptides that additionally incorporate changes that rendered the wild-type PH20 protein inactive (*e.g.*, truncations terminating below position 429, or single substitutions that render PH20<sub>1-447</sub> inactive).<sup>153</sup> That is because the *active* single-replacement PH20<sub>1-447</sub> polypeptides in the disclosure do not contain the distinct structural features that rendered the latter types of PH20 polypeptides enzymatically *inactive*. For example, an enzymatically active PH20<sub>1-447</sub> protein with a single amino acid substitution (*e.g.*, D320K) would not be considered representative of a PH20 terminating between positions 409 and 433 that also additionally contains the D320K substitution.<sup>154</sup> For example, the common disclosure does not identify and a skilled artisan could not have predicted from the single-replacement PH20<sub>1-447</sub> polypeptides examples in the common disclosure whether enzymatic activity could be restored to the

---

<sup>152</sup> EX1003, ¶¶ 146, 162.

<sup>153</sup> EX1003, ¶¶ 164-67.

<sup>154</sup> EX1003, ¶¶ 170-72.

truncated PH20 mutants, much less the precise additional changes necessary to do so.<sup>155</sup>

The common disclosure thus provides a very narrow set of working examples relative to the diversity of modified PH20 polypeptides being claimed.<sup>156</sup> The examples are restricted to *one type of change* (a single amino acid replacement) in *one type of PH20 polypeptide* (SEQ ID NO: 3).<sup>157</sup> By contrast, the claims encompass changes in 37 different unmodified PH20 sequences, and include, in addition to one identified replacement at position 320, anywhere from 1 to 41 (claim 1) or 22 (claim 2) or 20 (claims 24-25) additional changes.<sup>158</sup> A simple illustration demonstrates how *non-representative* the examples are: all of the examples of single-replacement PH20<sub>1-447</sub> mutants fit into one box of the array below (which depicts the scope of claim 2).

---

<sup>155</sup> EX1003, ¶ 171.

<sup>156</sup> EX1003, ¶ 158.

<sup>157</sup> EX1003, ¶¶ 100, 102, 106.

<sup>158</sup> EX1003, ¶¶ 118-23.

	Number of Changes																						
SEQ	1	2	3	4	5	6	7	8	9	10	11	12	13	14	15	16	17	18	19	20	21	22	23
3																							
7																							
32																							
33																							
34																							
35																							
36																							
37																							
38																							
39																							
40																							
41																							
42																							
43																							
44																							
45																							
46																							
47																							
48																							
49																							
50																							
51																							
52																							
53																							
54																							
55																							
56																							
57																							
58																							
59																							
60																							
61																							
62																							
63																							
64																							
65																							
66																							

Unlike claim 2, which requires 95% sequence identity, claim 1 permits 91% sequence identity, thus capturing an even *larger* genus (up to 42 permitted changes) than depicted above.

Consequently, a skilled artisan would not have viewed the Patents’ examples of individual single amino acid replacements in PH20<sub>1-447</sub> as being *representative* of the diversity of modified PH20 polypeptides encompassed by the claims.<sup>159</sup>

---

<sup>159</sup> EX1003, ¶ 146.

*g) The Claims Capture Multiply-Modified PH20 Polypeptides the Disclosure Excludes from the Class of Enzymatically Active PH20 Proteins*

Patentee's position on the breadth of the claims is unknown. However, by their literal language, they capture several sub-genera of modified PH20 polypeptides with changes that the common disclosure says rendered the PH20<sub>1-447</sub> mutants inactive (*i.e.*, single replacements in Tables 5/10 or in PH20 sequences terminating before position 429). Likewise, the claim language captures modified PH20 polypeptides with the six combinations of replacements the common disclosure explicitly says to not make: P13A/L464W, N47A/N131A, N47A/N219A, N131A/N219A, N333A/N358A, and N47A/N131A/N219A.<sup>160</sup> The claims thus improperly capture multiply-modified PH20 polypeptides the common disclosure affirmatively excludes from the genus of enzymatically active PH20 polypeptides.

The common disclosure provides no exemplification of multiply-modified species of PH20 polypeptides that disregard these restrictions in the common disclosure.<sup>161</sup> There is no explanation of the types of substitutions that might be made to restore activity that, under the logic of the common disclosure, will result

---

<sup>160</sup> See § V.A.1.b.i; EX1001, 77:45-57.

<sup>161</sup> EX1003, ¶ 164.

in enzymatically inactive PH20 polypeptides or which the specification teaches *not* to make.<sup>162</sup> Yet the claims encompass such proteins.

The claims thus independently violate the written description requirement for the reasons articulated by the Federal Circuit in *Gentry Gallery, Inc. v. Berklinc Corp.*, 134 F.3d 1473, 1479-80 (Fed. Cir. 1998)—if a disclosure “unambiguously limited” the invention, but the claims circumvent that limitation, those claims are “broader than the supporting disclosure” and are unpatentable.

## 2. **Dependent Claims 3-5, 16-23, and 26-40 Lack Written Description**

### *a) Claims 3-4*

Claims 3 and 4 specify additional functional properties of the modified PH20 polypeptides in the genus defined by claim 1: either (i) increased hyaluronidase activity (claim 4) or (ii) increased stability (claim 3) relative to unmodified PH20<sub>1-447</sub>.

The reasons provided in § V.A.1 explaining why the claims generally lack written description apply with full force to claims 3 and 4.

In addition, the common disclosure’s recitation of a *desired* level of stability or hyaluronidase activity in claims 3 and 4 does not identify *which* of the many trillions of PH20 polypeptides having 91% or 95% sequence identity with SEQ ID

---

<sup>162</sup> EX1003, ¶ 171.

NOS: 3, 7, or 32-66 and one of four replacements at position 320 will exhibit either of those functional properties.<sup>163</sup>

First, the identification of four single-substitution PH20<sub>1-447</sub> mutations at position 320 that exhibited increased activity compared to unmodified PH20<sub>1-447</sub> is not representative of each claim's genus of PH20 polypeptides having 1 to 41 additional substitutions and/or truncations.<sup>164</sup> Regarding "stability," none of the four position 320 mutants (D320H, D320K, D320R, and D320S) were tested.<sup>165</sup>

Second, the common disclosure identifies no common structural feature shared by multiply-modified PH20 polypeptides (if any) exhibiting increased activity or stability.<sup>166</sup> The mere presence of a single substitution at position 320 in a modified PH20 certainly does not demonstrate possession of any multiply-modified PH20 polypeptide with increased activity or stability having that position 320 substitution, and the common disclosure does not contend otherwise.<sup>167</sup>

---

<sup>163</sup> EX1003, ¶¶ 194, 201-202.

<sup>164</sup> EX1001, 252 (Table 9); EX1003, ¶¶ 201-202.

<sup>165</sup> EX1003, ¶ 71; *see* § V.A.1.c.ii.

<sup>166</sup> EX1003, ¶¶ 160, 194, 200.

<sup>167</sup> EX1003, ¶¶ 147, 171, 194.

The common disclosure does not describe any multiply-modified PH20 polypeptides having the claimed substitutions at position 320, much less those with 1 to 41 additional substitutions, and that exhibit increased enzymatic activity or increased stability.<sup>168</sup> Indeed, the common specification does not identify any multiply-modified PH20 polypeptides with any level of hyaluronidase activity.<sup>169</sup> Similarly, even if the data reported in Tables 11 and 12 was not flawed and unreliable as a measure of “stability” (as discussed above, it is), it too is limited to singly-substituted PH20 polypeptides, and, provides no “stability” data for multiply-modified PH20 polypeptides.<sup>170</sup>

Claims 3 and 4 lack written description in the common disclosure.

*b) Claims 5, 35*

Claims 5 and 35 require an additional functional property: that the modified PH20 polypeptide be “soluble.”

Claims 5 and 35 lack written description support (i) for the same reasons identified for claim 1, and (ii) because they encompass modified PH20 polypeptides that the common disclosure suggests would be insoluble.

---

<sup>168</sup> EX1003, ¶¶ 143, 194, 200-203.

<sup>169</sup> EX1003, ¶¶ 133, 181.

<sup>170</sup> EX1001, Tables 11, 12.

The common disclosure explains that “a soluble PH20 lacks all or a portion of a glycosphosphatidyl anchor (GPI) attachment sequence,”<sup>171</sup> which was known to be hydrophobic.<sup>172</sup> Citing prior art, it identifies the first residue of the GPI sequence in human PH20 as position 456 (position 491 in SEQ ID NO: 6).<sup>173</sup> It also states that a soluble PH20 “is a polypeptide that is truncated after amino acid 482 of ... SEQ ID NO: 6” (*i.e.*, 447 in SEQ ID NO:3).<sup>174</sup> It thus suggests that human PH20 sequences that terminate below position 448 are soluble while those terminating above position 456 are insoluble.<sup>175</sup>

Claims 5 and 35 encompass PH20 polypeptides based on SEQ ID NOS:59-66, which terminate between positions at 457 to 464 respectively (*i.e.*, beyond position 456). Both require a replacement at position 320, while claim 35

---

<sup>171</sup> EX1001, 46:31-33, 72:8-9, 74:26-38.

<sup>172</sup> EX1001, 72:32-44; EX1005, 86:18-22.

<sup>173</sup> EX1001, 72:32-44; *also* EX1005, 2:56-61 (“Attempts to make human PH20 DNA constructs that would not introduce a lipid anchor into the polypeptide resulted in either a catalytically inactive enzyme, or an insoluble enzyme”) (citing EX1011).

<sup>174</sup> EX1001, 75:16-18; EX1005, 3:57-62.

<sup>175</sup> EX1003, ¶¶ 92-93.

additionally requires a C-terminal truncation of any length. Consequently, claims 5 and 35 captures modified PH20 polypeptides that are C-terminally truncated but, per the common disclosure, **are not** “soluble modified PH20 polypeptide[s]” because each contains “all or a portion of” the GPI attachment sequence.<sup>176</sup>

Patentee may contend that some unidentified number of modified PH20 polypeptides based on SEQ ID NOS: 59-66 **may** be soluble, citing the common disclosure as suggesting that between 1-10 residues within the GPI anchor “can be retained, provided the polypeptide is soluble.”<sup>177</sup> But the common disclosure does not identify **which** modified PH20 polypeptides terminating above position 448 (and especially terminating between 457 and 464) **are** soluble, provides no examples of such soluble PH20 mutants, and provides no reason to expect that many modified PH20 polypeptides within the claim’s scope are soluble.

Thus, claims 5 and 35 are unpatentable for lack of written description for this additional, independent reason.

*c) Claims 16-23, 26-34*

Dependent claims 16-23 and 26-34 do not alter the number of PH20 polypeptides in the genus of claim 1. They instead specify additional features

---

<sup>176</sup> EX1001, 46:58-64.

<sup>177</sup> EX1001, 74:19-25.

(claims 16-22, 33-34), pharmaceutical compositions, or methods of treatment that reference the genus of claim 1. They lack written description for the same reasons explained in § V.A.1.<sup>178</sup>

*d) Claims 36-40*

Claims 36-40 concern methods of “increasing delivery of a therapeutic agent to a subject” (*e.g.*, an antibody) by administering any of the PH20 polypeptides within claim 1’s genus with the other agent (together or separately).

The common disclosure attributes PH20’s “increasing delivery” capability to its ability to cause “spreading” or “diffusion,” and indicates this “spreading” / “diffusion” capability requires a PH20 with hyaluronidase activity.<sup>179</sup> But, as explained in § V.A.1, the common disclosure does not identify which of the trillions of modified PH20 polypeptides within claim 1’s genus have hyaluronidase activity. Nor does it identify which of those trillions of polypeptides also possess “spreading” / “diffusion” activity—it identifies only one (F204P PH20<sub>1-447</sub>).<sup>180</sup>

Claims 36-40 lack written description.

---

<sup>178</sup> *Idenix*, 941 F.3d at 1155, 1165; *Boehringer*, PGR2020-00076, Paper 42, at 40-41.

<sup>179</sup> EX1001, 174:15-24, 175:17-30, 73:22-46.

<sup>180</sup> EX1001, 303:58-306:37.

The modified PH20 polypeptides within claim 1's genus also include those with multiple substitutions in the Hyal-EGF region of PH20. Before 2011, it was believed the Hyal-EGF domain mediated protein-protein interactions, and mutations to the Hyal-EGF domain substantially eliminated hyaluronidase activity in otherwise unaltered PH20 polypeptides.<sup>181</sup> Making multiple substitutions to the Hyal-EGF domain can alter its structure and thereby disrupt not only PH20's hyaluronidase activity but any protein-protein interactions that might be involved in PH20's spreading activity *in vivo*.<sup>182</sup>

Claims 36-40 thus also lack written description because the common disclosure does not identify which of the trillions of modified PH20 polypeptides with multiple substitutions in the Hyal-EGF domain retain hyaluronidase and/or "spreading" activity necessary for causing increased delivery.<sup>183</sup>

**B. All Challenged Claims Are Not Enabled**

All challenged claims are also unpatentable for lack of enablement.

---

<sup>181</sup> EX1003, ¶¶ 85-86, 89-90, 98; EX1006, 6912, 6913, 6916-17; EX1010, 9439; EX1005, 87:52-88:24; EX1079, 84.

<sup>182</sup> EX1003, ¶¶ 98-100, 173-177.

<sup>183</sup> EX1003, ¶ 178.

“If a patent claims an entire class of ... compositions of matter, the patent’s specification must enable a person skilled in the art to make and use the *entire* class,” *i.e.*, “the *full scope* of the invention,” and so the “more one claims, the more one must enable.”<sup>184</sup> “It is the specification, not the knowledge of one skilled in the art, that must supply the novel aspects of an invention in order to constitute adequate enablement.”<sup>185</sup> “Claims are not enabled when, at the effective filing date of the patent, one of ordinary skill in the art could not practice their full scope without undue experimentation.”<sup>186</sup>

Although not required, enablement may be assessed using the *Wands* factors, which consider: “(1) the quantity of experimentation necessary; (2) how routine any necessary experimentation is in the relevant field; (3) whether the patent discloses specific working examples of the claimed invention; (4) the

---

<sup>184</sup> *Amgen*, 598 U.S. at 610 (emphases added).

<sup>185</sup> *Idenix*, 941 F.3d at 1159.

<sup>186</sup> *Wyeth & Cordis Corp. v. Abbott. Labs*, 720 F.3d 1380, 1383-84 (Fed. Cir. 2013).

amount of guidance presented in the patent; (5) the nature and predictability of the field; (6) the level of ordinary skill; and (7) the scope of the claimed invention.”<sup>187</sup>

Where the scope of the claims is large, there are few working examples disclosed in the patent, and the only guidance to practice “the full scope of the invention [is] to use trial and error to narrow down the potential candidates to those satisfying the claims’ functional limitations—the asserted claims are not enabled.”<sup>188</sup>

Here, the common disclosure utterly fails to enable the immense genus of modified PH20 polypeptides claimed. Using that disclosure and knowledge in the prior art, the skilled artisan would have to perform undue experimentation to identify which of the  $10^{59}+$  PH20 polypeptides having multiple amino acid replacements and/or truncations within the scope of the claims are “active mutant” PH20 polypeptides.<sup>189</sup>

---

<sup>187</sup> *Idenix*, 941 F.3d at 1156 (citing *In re Wands*, 858 F.2d 731, 737 (Fed. Cir. 1988)).

<sup>188</sup> *Baxalta Inc. v. Genentech, Inc.*, 579 F. Supp. 3d 595, 615-16 (D. Del. 2022) (Dyk, T., sitting by designation) *aff’d* 81 F.4th 1362 (Fed. Cir. 2023).

<sup>189</sup> EX1003, ¶¶ 179-181, 200.

## 1. Claims 1-2, 6-15, and 24-25 Are Not Enabled

This case is a textbook example of claims that are not enabled under the reasoning articulated by the Supreme Court in *Amgen*. An analysis of the common disclosure under the Federal Circuit's framework for assessing undue experimentation using the factors in *In re Wands*, 858 F.2d 731 (Fed. Cir. 1988) compels the same conclusion.

### *a) Extreme Scope of the Claims*

As explained in § IV.D.1, each of claims 1-2, 6-15, and 24-25 define an immense and diverse genus of between  $10^{59}$  and  $10^{112}$  enzymatically active modified PH20 polypeptides. Practicing that full genus, however, raises substantial scientific questions left unanswered by the common disclosure:

- (i) The claims encompass many modified PH20 polypeptides that terminate below position 429.<sup>190</sup> The common disclosure and the prior art, however, report that unmodified human PH20 must include residues through position 429 to have hyaluronidase activity.<sup>191</sup>
- (ii) Several claims (1-2, 6-9) encompass modified PH20 polypeptides that, per the common disclosure's guidance, would be expected to be

---

<sup>190</sup> EX1003, ¶¶ 157, 167-169.

<sup>191</sup> EX1001, 69:66-70:8; EX1003, ¶¶ 96, 155-56.

insoluble because they include all or some of the GPI anchor sequence.<sup>192</sup>

- (iii) The mathematical “sequence identity” boundaries set by the claim language cause the claims to capture (without restriction) modified PH20 polypeptides with 2 to 42 amino acid replacements that the common disclosure instructs “are less tolerant to change or required for hyaluronidase activity”<sup>193</sup> or which the common disclosure affirmatively says to not make.<sup>194</sup>

In other words, the claims capture massive genera of modified PH20 polypeptides, most of which would have unknowable properties absent individual production and testing.<sup>195</sup>

Claims that capture a massive and diverse genus of proteins have routinely been found non-enabled. For example, the claims in *Amgen* covered “millions” of different, untested antibodies,<sup>196</sup> while in *Idenix*, a skilled artisan would

---

<sup>192</sup> EX1001, 46:31-33, 72:8-9, 74:19-25, 75:16-18; EX1005, 2:56-61, 3:57-62.

<sup>193</sup> EX1001, 80:13-15.

<sup>194</sup> EX1001, 77:45-57.

<sup>195</sup> EX1003, ¶¶ 159-161.

<sup>196</sup> 598 U.S. at 603.

“understand that ‘billions and billions’ of compounds literally meet the structural limitations of the claim.”<sup>197</sup> In both cases (as here), the enormous claim scope was contrasted to limited working examples in the patent, the field found unpredictable, and an immense quantity of experimentation was needed to practice the claims’ full scope (*Wands* Factors 1, 3, 4, and 7). As the *Idenix* court also observed, one cannot rely on the knowledge and efforts of a skilled artisan to try to “fill the gaps in the specification” regarding which of the “many, many thousands” of possible compounds should be selected for screening, and which in this case is impossible.<sup>198</sup>

*b) Limited Working Examples and Only a Research Plan for Discovering Active Mutant PH20 Polypeptides*

The common disclosure provides an extremely narrow set of working examples: ~5,917 randomly generated single-replacement PH20<sub>1-447</sub> polypeptides, of which ~2500 were “active mutants.”<sup>199</sup> Those examples are a tiny fraction of the 10<sup>59</sup> to 10<sup>112</sup> modified PH20 polypeptides covered by the claims, and provide no guidance that would help a skilled artisan navigate the “trial-and-error” methodology the common disclosure describes using to make modified PH20

---

<sup>197</sup> 941 F.3d at 1157.

<sup>198</sup> *Id.* at 1159.

<sup>199</sup> EX1003, ¶¶ 106-107.

polypeptides; indeed, none incorporate more than one substitution and none truncate the PH20 polypeptide before position 447.<sup>200</sup>

The common disclosure provides no credible guidance on the full scope of the genus comprising multiple combinations of changes to PH20 polypeptides.<sup>201</sup> Instead, it describes an explicitly prophetic and “iterative” process for *discovering* active mutant PH20 polypeptides. *See* § V.A.1.d.

This prospective research plan requires a skilled artisan to engage in undue experimentation to practice the full scope of the claims. First, it requires manually performing iterative rounds of *randomized* mutations (up to 41 rounds per starting molecule under the broadest claims) to *discover* which of the 10<sup>59</sup>+ possible modified PH20 polypeptides the claims encompass might possess hyaluronidase activity.<sup>202</sup>

---

<sup>200</sup> EX1003, ¶¶ 158-162, 170.

<sup>201</sup> EX1003, ¶¶ 134, 142.

<sup>202</sup> EX1003, ¶¶ 188-90; *see also* EX1018, 382 (“combinatorial randomization of only five residues generates a library of 205 possibilities (3.2 x 10<sup>6</sup> mutants), too large a number for manual screening”). Chica credited a “ground-breaking” predictive molecular modeling technique that was later shown to be

Second, it provides no meaningful guidance about producing “active mutant” modified PH20 polypeptides:

- (i) it does not identify *any* specific combination of two or more replacements within any PH20 polypeptide that yield “active mutants”;
- (ii) it provides no data from testing *any* PH20 polypeptide with two or more substitutions; and
- (iii) it does not identify any regions or residues that are “associated with the activity and/or stability of the molecule” or “critical residues involved in structural folding or other activities’ of the molecule” when two or more concurrent replacements have been made.<sup>203</sup>

From the common disclosure and their knowledge in 2011, a skilled artisan could not predict whether a particular multiply-modified PH20 polypeptide will be enzymatically active without making and testing each one.<sup>204</sup>

---

false. EX1018, 384, 382; EX1030, 569; EX1034, 258; EX1036, 275, 277; EX1048, 859.

<sup>203</sup> EX1003, ¶¶ 147, 161, 181, 193-194.

<sup>204</sup> EX1003, ¶¶ 199-200, 203.

Regardless whether individual rounds of “iterative” production and testing might be considered “routine,” the process described in the common disclosure is indistinguishable from the “*iterative, trial-and-error process[es]*” that have consistently been found to not enable broad genus claims to modified proteins.<sup>205</sup> Simply put, the common disclosure’s prophetic, iterative and labor-intensive process requires making and screening an immense number of modified PH20 polypeptides, before which the skilled artisan will not know which multiply-modified PH20 polypeptides are within the claims’ scope.<sup>206</sup>

*c) Making Multiple Changes to PH20 Polypeptides Was Unpredictable*

Like any protein, the activity of PH20 can be unpredictably influenced by changes to its amino acid sequence.<sup>207</sup> Introducing changes can alter the local structure of the protein where the change is made, which may disrupt secondary

---

<sup>205</sup> *Idenix*, 941 F.3d at 1161-63 (emphasis added); *see also Amgen*, 598 U.S. at 612-15; *Wyeth*, 720 F.3d at 1384-86; *Baxalta*, 597 F. Supp. 3d at 616-19; *McRO, Inc. v. Bandai Namco Games Am. Inc.*, 959 F.3d 1091, 1100 n.2 (Fed. Cir. 2020).

<sup>206</sup> EX1003, ¶¶ 175, 192-194, 199.

<sup>207</sup> EX1003, ¶ 61.

structures or structural motifs within the protein that are important to its biological activity (*e.g.*, catalysis, ligand binding, etc.) and/or stability.<sup>208</sup>

As explained in § VI below, by 2011, skilled artisans could have assessed whether certain *single* amino acid substitutions at certain positions would be tolerated within the PH20 protein structure with a reasonable (though not absolute) expectation of success.<sup>209</sup> That person, using a rational design approach, would have performed such an assessment by, *inter alia*, analyzing evolutionarily non-conserved positions and evaluating specific changed residues using a PH20 protein structure model using experimental evidence available before 2011 that is not disclosed in or referenced by the common disclosure.<sup>210</sup>

By contrast, the skilled artisan could *not* have predicted the effects of making more than a few concurrent amino acid replacements within a PH20 polypeptide in 2011.<sup>211</sup> Introducing *multiple* concurrent changes into a particular region of a protein greatly increases the likelihood of disrupting secondary structures and structural motifs essential to the protein's activity and/or stability,

---

<sup>208</sup> EX1003, ¶¶ 61, 201-202.

<sup>209</sup> EX1003, ¶ 204.

<sup>210</sup> EX1003, ¶¶ 20, 49.

<sup>211</sup> EX1003, ¶¶ 161, 239.

and can even introduce new ones into the protein.<sup>212</sup> Replacing multiple amino acids thus can introduce an immense number of simultaneous influences on a protein's structure that cannot be predicted.<sup>213</sup>

The cumulative effects of multiple changes would also have rapidly exceeded the capacity of computer-based, rational design protein engineering techniques to reliably predict the effects of each change on the protein's structure in 2011. For example, the further away the modeled amino acid sequence gets from an actual naturally occurring sequence and/or the original model's structure, the less reliable that model became.<sup>214</sup> In addition, depending on the structural template used to produce the model, regions of the protein not supported by a corresponding structure cannot be reliably used to assess particular changes.<sup>215</sup> And the time required to carry out rational design techniques to "practice" the full scope of the claimed genus would be unimaginable.<sup>216</sup>

---

<sup>212</sup> EX1003, ¶¶ 59-60, 194.

<sup>213</sup> EX1003, ¶¶ 55, 58, 61.

<sup>214</sup> EX1003, ¶¶ 161, 200, 239; EX1004, ¶¶ 161-162.

<sup>215</sup> EX1003, ¶¶ 161, 239; EX1004, ¶¶ 151-153; EX1012, 4, 8.

<sup>216</sup> EX1003, ¶¶ 51, 200; EX1059, 1225-26; EX1018, 378.

Consequently, a skilled artisan could not have used conventional rational design techniques to identify, much less predict the outcome of attempts to make, the enormous number of PH20 polypeptide sequences that incorporate the myriad possible combinations of between 2 and up to 42 substitutions the claims encompass.<sup>217</sup> Stated another way, practicing the full scope of the claims would have been well beyond the ability of the skilled artisan's ability to reasonably predict which multiply-modified PH20 polypeptides would be enzymatically active, and, even if possible, doing so would have taken an extreme amount of time and effort even for a small handful of the vast universe of multiply-modified polypeptides within the claims.<sup>218</sup>

*d) Other Wands Factors and Conclusion*

The remaining *Wands* factors either support the conclusion that practicing the full scope of the claims would require undue experimentation or are neutral.

For example, while a skilled artisan was highly skilled, the field of protein engineering was unpredictable and tools did not exist that permitted accurate modeling of the range of multiply-changed PH20 polypeptides being claimed.<sup>219</sup>

---

<sup>217</sup> EX1003, ¶¶ 61, 161, 239.

<sup>218</sup> EX1003, ¶¶ 161, 200.

<sup>219</sup> EX1003, ¶¶ 161, 239.

Likewise, while there was significant knowledge in the public art about hyaluronidases, there was no solved structure of the PH20 protein, experimental reports generally reported on *loss of activity* from mutations, and did not predictably teach how to introduce changes that *enhanced* stability or activity. Indeed, the non-enabled patent disclosure at issue in *Amgen* dates to the same 2011 timeframe as the common disclosure.

Practicing the full scope of claims 1-2, 6-15, and 24-25 thus would have required a skilled artisan to engage in undue experimentation, which renders those claims non-enabled.

## **2. Dependent Claims 3-5, 16-23, and 26-40 Are Not Enabled**

### *a) Claims 3-4*

Claims 3 and 4 require the modified PH20 polypeptides to have increased activity (*i.e.*, >100% of unmodified PH20) or increased resistance to or stability in denaturing conditions.

Claims 3 and 4 are not enabled for the same reasons that claims 1-2, 6-15, and 24-25 are not enabled (*see* § V.B.1). Specifically, a skilled artisan could not have predicted which of the trillions of PH20 polypeptides having up to 41 changes beyond a required change at position 320 would exhibit increased activity or

stability relative to unmodified PH20.<sup>220</sup> Instead, a skilled artisan would need to make-and-test each molecule in order to practice the “full scope” of the claims.<sup>221</sup>

*b) Claims 5, 35*

Claims 5 and 35 require “soluble” forms of PH20. Because both claims encompass a substantial portion of the genus of claim 1, they are not enabled for the same reasons.

Additionally, as explained in § V.A.2.b, the common disclosure suggests that PH20 polypeptides extending past position 456 are “insoluble.” A skilled artisan would have expected the presence of the hydrophobic GPI sequence in a PH20 protein to cause aggregation, loss of activity, and/or reduced expression.<sup>222</sup> The common disclosure recognizes these problems, but provides no solution or examples of modified PH20 polypeptides extending past position 456 that are soluble. Claims 5 and 35 are thus not enabled.

*c) Claims 16-23, 26-34*

Claims 16-23 and 26-34 employ the genus definition used in claim 1 and recite either further modifications to the modified polypeptides, pharmaceutical

---

<sup>220</sup> EX1003, ¶¶ 194, 200.

<sup>221</sup> *Id.*

<sup>222</sup> EX1003, ¶¶ 92-93, 206, 233.

compositions, or methods of treatment using the claimed genus. These claims do not add requirements that limit the numbers of polypeptides in the claim 1 genus. They are therefore not enabled for the same reasons.<sup>223</sup>

*d) Claims 36-40*

Claims 36-40 encompass methods of increasing delivery of a therapeutic agent using any of the modified PH20 polypeptides within claim 1's genus.

The common disclosure indicates that a modified PH20 must possess hyaluronidase activity to be capable of increasing delivery of a therapeutic agent.<sup>224</sup> Because the common specification does not enable claim 1's genus of "active mutant" modified PH20 polypeptides (*see* § V.B.1), it cannot enable methods dependent on using any "active mutant" modified PH20 polypeptides within claim 1's genus.

Claims 36-40 are not enabled for another reason. The common disclosure attributes the PH20's "increased delivery" capability to its ability to cause "spreading" / "diffusion."<sup>225</sup> The common disclosure then explains that one can determine if any modified PH20 polypeptide can cause "spreading" by testing it in

---

<sup>223</sup> *See, e.g., Idenix*, 941 F.3d at 1155, 1165.

<sup>224</sup> EX1001, 174:15-24, 175:17-30, 73:22-46.

<sup>225</sup> *See* § V.A.2.d; EX1001, 174:15-24, 175:17-30, 73:22-46.

an *in vivo* assay: “[t]he ability of a PH20 polypeptide ... to act as a spreading or diffusing agent can be assessed” using a specified *in vivo* experiment using a mouse.<sup>226</sup> Notably, this is a different test than the *in vitro* assay used to detect hyaluronidase activity.<sup>227</sup> And, the common disclosure identifies only one mutant as having this “spreading” capability responsible for PH20’s ability to increase delivery of a therapeutic agent.<sup>228</sup>

In other words, to determine which of the trillions of modified PH20 polypeptides within claims 1’s genus can be used in the claimed method of increasing delivery of another agent of claims 36-40, a skilled artisan must make and test each of the mutants in a mouse experiment.<sup>229</sup> Practicing the full scope of claims 36-40, thus, would require a skilled artisan to engage in an impossible amount of “make and test” experiments, rendering each of those claims not enabled.

---

<sup>226</sup> EX1001, 172:33-53, 292:34-67; EX1003, ¶¶ 174-175, 177.

<sup>227</sup> EX1001, 188:66-189:14, 224:50-226:43; EX1003, ¶ 192.

<sup>228</sup> EX1001, 303:58-306:36.

<sup>229</sup> EX1003, ¶ 195.

**C. Inactive PH20 Polypeptides Are Not Useful and Do Not Remedy the § 112(a) Deficiencies of the Claims**

Patentee may contend the claims do not require the modified PH20 polypeptides to be “active mutants.” Such a contention, even if accepted, does not solve the written description and enablement problems of the claims.

First, it ignores that at least *a portion* of the claimed genus *does* require the modified PH20 polypeptides to be “active mutants.” *See* § V.B.2.a. Claim 4 defines a “sub-genus” of modified PH20 polypeptides that is within the scope of claim 1 and that must exhibit increased hyaluronidase activity. The failure of the common disclosure to enable or describe that subgenus demonstrates that claim 1 is unpatentable.<sup>230</sup>

Second, the common disclosure provides no correlation between multiply-modified PH20 polypeptides and *either* active *or* inactive mutants.<sup>231</sup> The skilled artisan thus must perform trial-and-error testing of each of the 10<sup>59</sup>+ candidate

---

<sup>230</sup> *ABS Glob., Inc. v. Inguran*, 914 F.3d 1054, 1070, 1074 (7th Cir. 2019) (citing *Alcon Research, Ltd. v. Apotex, Inc.*, 687 F.3d 1362, 1367-68 (Fed. Cir. 2012)).

<sup>231</sup> EX1003, ¶ 147.

polypeptides within the claims' scope to determine which are "active mutants" and which are "inactive mutants."<sup>232</sup>

Third, the only putative utility identified for "inactive" polypeptides is as "antigens in contraception vaccines."<sup>233</sup> That assertion is not scientifically credible. While the specification cites two studies in guinea pigs,<sup>234</sup> it ignores numerous publications before 2011 that showed that immunizing mammals with PH20 did *not* cause contraception.<sup>235</sup> Moreover, Patentee reported that clinical studies of unmodified PH20<sub>1-447</sub> in 2018 showed that "[a]lthough some antisperm antibodies are associated with decreased fertility [], no evidence of negative effects on fertility could be determined in rHuPH20-reactive antibody-positive subjects of

---

<sup>232</sup> EX1003, ¶¶ 182-83, 191-93.

<sup>233</sup> EX1001, 75:56-58, 187:47-67.

<sup>234</sup> EX1001, 187:47-67; EX1022, 1142-43; EX1023, 1133-34.

<sup>235</sup> See EX1019, 325, 331-33 ("recombinant mPH20 is not a useful antigen for inclusion in immunocontraceptive vaccines that target mice"); EX1020, 179-81 ("immunization [of rabbits] with reproductive antigens ... are unlikely to result in reduced fertility ..."); EX1021, 30310, 30314 ("PH-20 is not essential for fertilization, at least in the mouse ...").

either sex.”<sup>236</sup> Notably, Patentee publicly reported this clinical result before filing the application that issued as the ’652 Patent. A skilled artisan thus would have expected that “inactive mutant” PH20 polypeptides would have no utility at all,<sup>237</sup> and would not have accepted the common disclosure’s assertion that “inactive mutants” are useful as contraceptive vaccines, particularly in humans.<sup>238</sup>

Finally, the common disclosure does not identify *any* inactive PH20 mutants that exhibit contraceptive effects in humans (contrary to patentee’s clinical evidence).<sup>239</sup> It likewise provides no guidance about which epitopes (if any) on the PH20 protein might induce contraceptive effects, much less show that “inactive mutants” preserve such epitopes.<sup>240</sup> Thus, a skilled artisan could not have reasonably predicted from the common disclosure whether any “inactive mutant”

---

<sup>236</sup> EX1024, 87-88; *see also* EX1061, 1154; EX1003, ¶¶ 113-14.

<sup>237</sup> EX1003, ¶¶ 113-14; *Atlas Powder Co. v. E.I. du Pont de Nemours & Co.*, 750 F.2d 1569, 1576-77 (Fed. Cir. 1984); *Pharm. Res., Inc. v. Roxane Labs., Inc.*, 253 F. App’x. 26, 30 (Fed. Cir. 2007).

<sup>238</sup> EX1003, ¶¶ 115-16; *See Rasmusson v. SmithKline Beecham Corp.*, 413 F.3d 1318, 1323 (Fed. Cir. 2005).

<sup>239</sup> EX1003, ¶ 116.

<sup>240</sup> *Id.*

PH20 polypeptides would contain such (unidentified) epitopes or induce antibody production sufficient to confer contraceptive effects.<sup>241</sup>

Therefore, at most, the common disclosure presents only a “research proposal” to discover “inactive mutants” with contraceptive utility, which is insufficient.<sup>242</sup> It does not demonstrate possession of or enable the immense and diverse genus of PH20 polypeptides claimed, regardless of whether the claims are appropriately limited to “active mutants” or, instead, include “inactive mutants.”

**D. The Original Claims of the ’731 Application Do Not Cure the Written Description and Enablement Deficiencies**

The specifications of the pre-AIA ’731 Application and AIA ’652 Patent are substantially identical, and neither supports the challenged claims as § 112(a) requires. The claims are both PGR eligible and unpatentable under § 112(a).

The original claims of the ’731 Application provide no additional guidance demonstrating written description or enablement of the claimed genera of multiply-modified PH20 polypeptides. Those original claims claimed equivalently broad genera via sequence identity language (*e.g.*, 85% to SEQ ID NOS: 3, 7, or 32-66) (claims 1-3) or having up to “75 or more amino acid replacements” (claim 4).

---

<sup>241</sup> EX1003, ¶¶ 115-16.

<sup>242</sup> *See Janssen Pharmaceutica N.V. v. Teva Pharms. USA, Inc.*, 583 F.3d 1317, 1324 (Fed. Cir. 2009).

Dependent claims listed single positions (claim 12) or replacements (claims 13-16) in those polypeptides. And, while certain claims contemplated 2-3 particular combinations of amino acid replacements (from dozens listed), others encompassed substitutions at unspecified locations.<sup>243</sup> The original claims do not provide § 112 support for the challenged claims.<sup>244</sup>

## **VI. Challenged Claims 1-2, 5-40 Are Unpatentable Under § 103**

The claims define genera that encompass at least one specific modified PH20 polypeptide: D320K PH20<sub>1-447</sub> (claims 1-2, 5-6, 8-40) or D320S (claims 1-2, 5, 7-8, 10-11, 14, 16-23, 26-40). *See* § IV.D.2. Because each mutant would have been obvious from the '429 Patent in view of Chao and the knowledge of a skilled artisan, each of those claims is unpatentable. Claims 5, 16-23, and 26-40 are also obvious, as each recites attributes met by D320K and D320S PH20<sub>1-447</sub>, or is suggested by the '429 Patent alone or with other prior art.

### **A. The Prior Art**

The '429 Patent (EX1005) is owned by Patentee, was originally filed in 2003, and issued on Aug. 3, 2010.

---

<sup>243</sup> EX1026, at 335.

<sup>244</sup> *See, e.g., Ariad Pharms.*, 598 F.3d at 1349; *Fiers v. Revel*, 984 F.2d 1164, 1170-71 (Fed. Cir. 1993).

Chao (EX1006) was published in “Biochemistry” in 2007. Chao is not discussed in the common disclosure of the ’652 Patent and ’731 Application and was not cited during examination.

Knowledge of the skilled artisan relevant to obviousness is described in the testimony of Drs. Hecht (EX1003) and Park (EX1004), and is also documented in the prior art, including Patentee’s earlier-published application, WO297 (EX1007).

**B. Because D320K and D320S PH20<sub>1-447</sub> Would Have Been Obvious, Claims 1-2, 6-15, and 24-25 Are Unpatentable**

Patentee’s ’429 Patent would have motivated a skilled artisan to produce modified PH20<sub>1-447</sub> polypeptides having a single amino acid substitution in non-essential regions of the protein. Guided by her familiarity with rational protein design and the teachings of the ’429 Patent and Chao, the artisan would have readily identified single amino acid substitutions in non-essential regions of PH20<sub>1-447</sub> that would have been tolerated (*i.e.*, a PH20<sub>1-447</sub> with that single substitution would retain its enzymatic activity). D320K and D320S PH20<sub>1-447</sub> are two such examples. Because claims 1-2, 6-15, and 24-25 encompass at least one of these obvious variants of PH20<sub>1-447</sub>, each is unpatentable.

**1. Patentee’s ’429 Patent Motivates a Skilled Artisan to Make Single Amino Acid Substitutions in Non-Essential Regions of PH20<sub>1-447</sub>**

Patentee’s ’429 Patent, filed in 2003, describes its invention as soluble PH20 hyaluronidase glycoproteins (“sHASEGPs”) that are enzymatically active at

neutral pH.<sup>245</sup> It exemplifies and claims one such “sHASEGP” that terminates at position 447 (positions 36-482 of SEQ ID NO: 1).<sup>246</sup>

The '429 Patent explains that sHASEGPs are useful in human therapy, including, *inter alia*, in pharmaceutical compositions, and combined with other therapeutic agents (*e.g.*, antibodies, chemotherapeutics), and illustrates administering such combinations subcutaneously to treat cancer and hyaluronidase disorders.<sup>247</sup> PH20<sub>1-447</sub> was approved by the FDA as Hylenex<sup>®</sup> in 2005.<sup>248</sup> The '429 Patent's teachings combined with the status of PH20<sub>1-447</sub> as an approved human therapeutic before 2011 would have induced a skilled artisan to focus on this particular PH20 polypeptide.<sup>249</sup>

---

<sup>245</sup> EX1005, 6:4-10, 10:30-59.

<sup>246</sup> EX1005, 86:18-33, 86:64-87:13, 88:8, 89:52-90:15, 153:36-40.

<sup>247</sup> EX1005, 8:25-9:4, 54:40-65, 56:34-57:36, 60:38-61:4, 63:41-61, 74:10-29, 76:19-77:36, 99:28-100:47.

<sup>248</sup> EX1049, 1.

<sup>249</sup> EX1003, ¶ 205.

Patentee's '429 Patent defines sHASEGPs as including wild-type PH20<sub>1-447</sub> and "equivalent" proteins "with amino acid substitutions that do not substantially alter activity" of the protein.<sup>250</sup> It explains:

Suitable conservative substitutions of amino acids are known to those of skill in this art and can be made generally without altering the biological activity, for example enzymatic activity, of the resulting molecule. Those of skill in this art recognize that, in general, single amino acid substitutions in non-essential regions of a polypeptide do not substantially alter biological activity ...<sup>251</sup>

The '429 Patent also explains that single amino acid substitutions can include "conservative" substitutions in Table 1, but that "[o]ther substitutions are also permissible and can be determined empirically or in accord with known conservative substitutions."<sup>252</sup>

The '429 Patent thus teaches making a *particular* type of modification (a single amino acid substitution) in *particular* locations (non-essential regions of PH20) in a *particular* PH20 sequence (PH20<sub>1-447</sub>) to yield equivalents of PH20<sub>1-447</sub>

---

<sup>250</sup> EX1005, 9:65-10:13; *see also id.* at 18:64-19:6 ("equivalent" proteins).

<sup>251</sup> EX1005, 16:14-22.

<sup>252</sup> EX1005, 16:24-36.

(i.e., those that do not substantially alter the activity or function of PH20<sub>1-447</sub>).<sup>253</sup>

The '429 Patent also motivates skilled artisans to undertake this effort to design and produce such single-amino acid substituted PH20<sub>1-447</sub> proteins because it assures them their efforts will be successful.<sup>254</sup> As it states, skilled artisans recognized that such “single amino acid substitutions in non-essential regions” of PH20<sub>1-447</sub> “do not substantially alter biological activity” of PH20<sub>1-447</sub>.<sup>255</sup> As such, a skilled artisan would have expected a PH20<sub>1-447</sub> mutant with a single amino acid substitution in a non-essential region to have the same utility, therapeutic applications, and other characteristics that the '429 Patent identifies for wild-type PH20<sub>1-447</sub> and other sHASEGPs.<sup>256</sup>

## **2. Chao Provides Information Useful for Engineering the Changes to PH20<sub>1-447</sub> that the '429 Patent Suggests**

In 2011, a skilled artisan looking to implement the '429 Patent's suggestion to make a single-amino acid modification in a non-essential region of PH20<sub>1-447</sub> would have recognized such changes could best be accomplished using rational design, which here involves determining (i) which regions are non-essential in

---

<sup>253</sup> EX1003, ¶ 216; EX1004, ¶ 32.

<sup>254</sup> EX1003, ¶ 217.

<sup>255</sup> EX1005, 16:4-21.

<sup>256</sup> EX1003, ¶¶ 209-212, 217, 233.

PH20, and (ii) which single amino acids to substitute into positions in those non-essential regions.<sup>257</sup>

The '429 Patent was written eight years before 2011. Given that, a skilled artisan would have looked for additional published insights into the structure of human hyaluronidase enzymes like PH20, like Chao (EX1006).<sup>258</sup> Chao reported an experimentally determined structure for human HYAL1 and provided new insights into the shared characteristics of human hyaluronidase enzymes.<sup>259</sup>

First, by superimposing HYAL1 and bee venom hyaluronidase structures, Chao showed that human and non-human hyaluronidases share a highly conserved active site and identified residues in it that interact with HA.<sup>260</sup>

---

<sup>257</sup> EX1003, ¶¶ 222-24.

<sup>258</sup> EX1003, ¶¶ 88, 219-221; EX1004, ¶ 88.

<sup>259</sup> EX1003, ¶¶ 81-88; EX1004, ¶ 88; EX1006, 6912-17.

<sup>260</sup> EX1006, 6917 (Figure 4A); *see also id.* at 6914-16, Figure 2C; EX1004, ¶¶ 89-91; EX1003, ¶¶ 81-82.

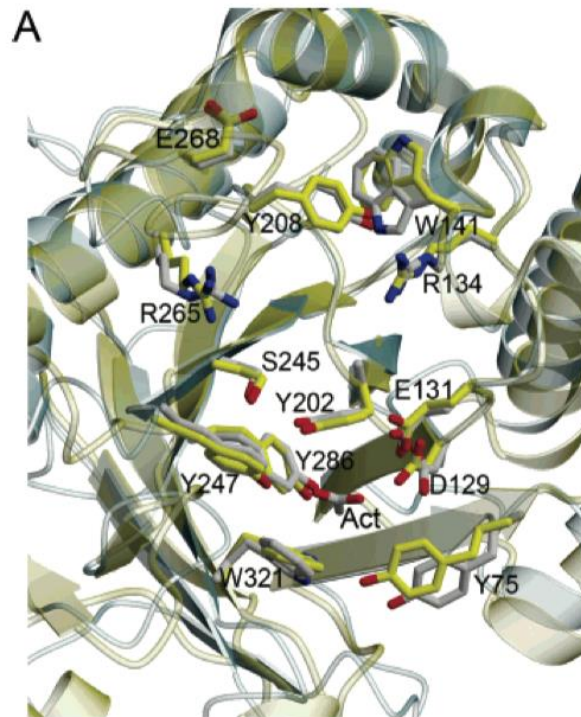

The '429 Patent likewise used the bee venom hyaluronidase structure to identify critical residues in PH20,<sup>261</sup> and taught that hyaluronidase domains share similarity among species, including residues necessary for enzymatic activity.<sup>262</sup>

Second, using an alignment of five human hyaluronidases, Chao identified predicted secondary structures (*e.g.*,  $\beta$ -sheets,  $\alpha$ -helices) (Figure 3, below), as well as invariant conserved positions (blue), residues involved in catalysis (red),

---

<sup>261</sup> EX1005, 4:12-22, 86:49-53, 88:14-24.

<sup>262</sup> EX1005, 2:6-67, 4:11-22.

conserved cysteines that form disulfide bonds (gold) and conserved asparagine residues that are glycosylated (turquoise).<sup>263</sup>

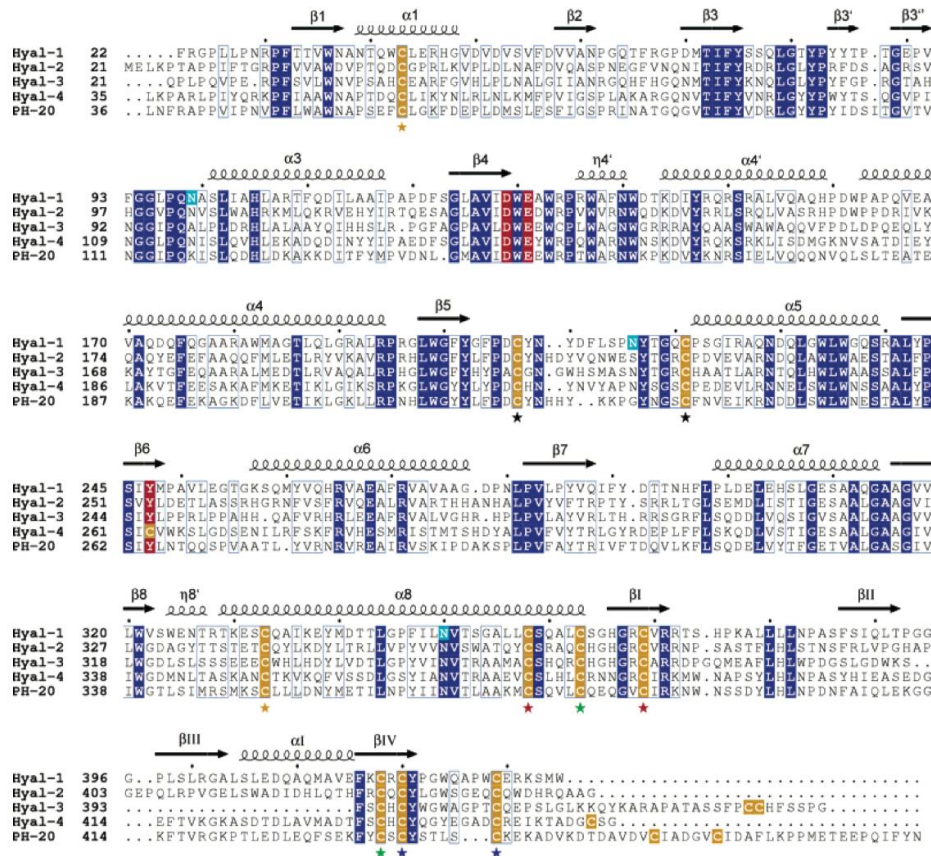

FIGURE 3: Structure-based sequence alignment of human hyaluronidases. Invariant residues are shown in blue except for three key catalytic residues that are colored red. The hHyal-1 N-glycosylated asparagines residues are colored turquoise. Residues exhibiting conservative replacements are blocked in blue. Pairs of cysteine residues that form disulfide bonds are indicated by stars with matching colors. Secondary structure units are labeled as in Figure 2B.

Third, Chao reported the presence of “a novel, EGF-like domain” in the C-terminal region of human hyaluronidases that was “closely associated” with the

<sup>263</sup> EX1006, 6916; EX1003, ¶¶ 83, 221; EX1004, ¶ 92.

catalytic domain (discussed above, § V.A.1.b.iii), and identified a characteristic pattern for the Hyal-EGF domain in PH20 at positions 337-409.<sup>264</sup>

**3. A Skilled Artisan Would Have Identified Position 320 as Being in a Non-Essential Region of PH20<sub>1-447</sub> in 2011**

To implement the '429 Patent's suggestion to produce modified PH20<sub>1-447</sub> polypeptides with single amino acid substitutions in non-essential regions that retain hyaluronidase activity, the skilled artisan would first identify the essential residues in PH20 by comparing proteins homologous to PH20 that were known in 2011.<sup>265</sup> The artisan would have done that using conventional sequence alignment tools in conjunction with the information in the '429 Patent and in Chao, as well as information publicly known in 2011.<sup>266</sup>

A multiple-sequence alignment identifies non-essential regions in PH20—the sequences between essential residues—and positions at which variations occur at a frequency above ~5% (illustrated below).<sup>267</sup>

---

<sup>264</sup> EX1006, 6911; EX1004, ¶¶ 97-98; EX1003, ¶¶ 84, 87.

<sup>265</sup> EX1003, ¶¶ 222-224; EX1004, ¶¶ 22, 25-30, Appendix D-3.

<sup>266</sup> EX1003, ¶¶ 20-21, 223-225; EX1004, ¶¶ 22-24; EX1017, 224-26.

<sup>267</sup> EX1004, ¶¶ 31-32, Appendix D-2; EX1003, ¶¶ 223-224; EX1006, 6916.

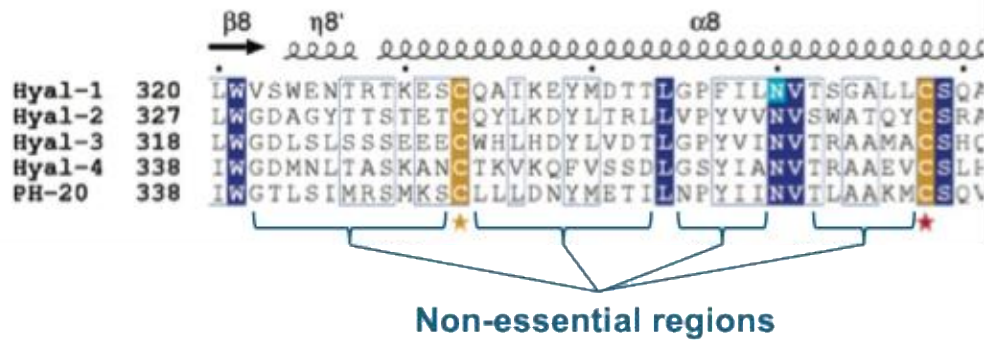

Dr. Sheldon Park, an expert in protein sequence and structure analysis with extensive personal experience before 2011, performed these steps. He identified 88 homologous hyaluronidase protein sequences published by December 29, 2011.<sup>268</sup> Then he prepared a multiple-sequence alignment of these sequences, as Chao did with the five human hyaluronidases, and from that alignment identified essential (Appendix D-3) and non-essential (Appendix D-2) residues.<sup>269</sup>

Position 320 is within a non-essential region of PH20<sub>1-447</sub>, which is shown by Dr. Park's analysis and by Chao's Figure 3; both report the same bounding essential residues (*i.e.*, C316 and L327) (below).<sup>270</sup>

<sup>268</sup> EX1004, ¶¶ 27, 143-146; EX1053; EX1054; EX1055; EX1056; EX1064, 1, 4, 10, 23-28.

<sup>269</sup> EX1004, ¶¶ 28-32, 147-148, Appendix D; EX1057; EX1058; EX1043, 1-2, 4-5; EX1065, 1, 4.

<sup>270</sup> EX1003, ¶ 227; EX1004, ¶¶ 31-32, Appendix D-2; EX1006, 6916.

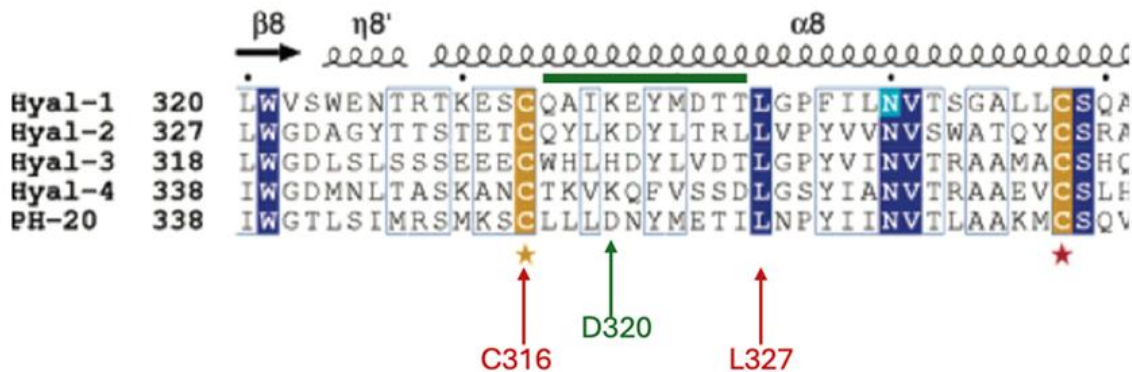

Following the guidance and information in the '429 Patent and Chao, and assessing information publicly available in December 2011 using conventional sequence analysis tools, a skilled artisan would have readily identified position 320 as a position within a non-essential region PH20<sub>1-447</sub>.<sup>271</sup>

**4. A Skilled Artisan Would Have Viewed Lysine and Serine as Obvious Single Amino Acid Substitutions for Aspartic Acid at Position 320 of PH20<sub>1-447</sub>**

The multiple-sequence alignment reveals a second powerful insight: it identifies *which* amino acids have been tolerated at specific positions in the amino acid sequence of homologous, stable and active, naturally occurring hyaluronidase enzymes.<sup>272</sup> This derives from evolutionary selection principles, which over the

<sup>271</sup> EX1003, ¶ 231; EX1004, ¶¶ 31-32, 104, Appendix D-2; EX1005, 16:14-22, 16:24-36; EX1006, 6916.

<sup>272</sup> EX1003, ¶ 224; EX1004, ¶¶ 21-22.

course of millions of years, function to eliminate from the genome of organisms those variations in the sequences of a protein that do not yield stable and active forms of the protein.<sup>273</sup>

Using a multiple-sequence alignment, a skilled artisan can readily compile a list of amino acids tolerated at positions within non-essential regions of PH20.<sup>274</sup> Dr. Park did this: using his multiple-sequence alignment of the 88 hyaluronidase proteins known by December 2011, he identified the different amino acids that occur at positions corresponding to position 320 in PH20 in homologous hyaluronidases, and how many proteins contain each residue (below).<sup>275</sup>

---

<sup>273</sup> EX1003, ¶ 224; EX1004, ¶¶ 25, 31, 41-42; EX1017, 224 (evolutionarily conserved sequences useful for determining protein structure and function); EX1014, 351.

<sup>274</sup> EX1003, ¶¶ 224-225; EX1004, ¶¶ 21-22.

<sup>275</sup> EX1004, ¶¶ 30-32, 41-43, 106, 116, Appendix D-1; EX1003, ¶¶ 225, 227-228.

		AA at position 355/320 in PH20 <sub>1-447</sub>		Most frequent AA at position in set of proteins	
wt 355:	D	10.22	K	57.95	
res394:	K	51	57.95		] % of occurrence of AA in set of proteins
res394:	D	9	10.22		
res394:	H	9	10.22		
res394:	R	5	5.68		
res394:	N	5	5.68		
res394:	Q	4	4.54		
res394:	S	2	2.27		
res394:	G	2	2.27		
res394:	E	1	1.13		

The wild-type residue at position 320 in PH20 is aspartic acid (D), which occurs in ~10% of the proteins (including PH20). The most prevalent amino acid found at position 320 in this set of homologous sequences is lysine (K) (57.95%), which is present in 51 different hyaluronidase proteins.<sup>276</sup> Serine is also present in 2 known homologous hyaluronidase proteins.

A skilled artisan would have considered position 320 to be a position within a non-essential region of PH20<sub>1-447</sub> at which a single amino acid substitution could be made pursuant to the guidance in the '429 Patent.<sup>277</sup> The skilled artisan also

<sup>276</sup> EX1004, ¶ 116; EX1003, ¶ 228.

<sup>277</sup> EX1003, ¶¶ 227, 231.

would have selected lysine (K) or serine (S) as obvious choices for such a single substitution at position 320 in PH20<sub>1-447</sub>.<sup>278</sup>

First, lysine is the most prevalent amino acid at positions corresponding to 320 in PH20: it occurs in nearly 60% of the 88 homologous hyaluronidase enzymes known by 2011 (51 different naturally occurring hyaluronidase enzymes) and in 3 of the 5 human hyaluronidases (as shown in Chao Figure 3, above).<sup>279</sup> Lysine's high frequency at positions corresponding to 320 in naturally occurring hyaluronidases indicates it is likely to be tolerated in PH20, and makes it an obvious amino acid to substitute into position 320 of PH20.<sup>280</sup>

Second, lysine was known to be favored in sequences that form  $\alpha$ -helix secondary structures due to its high helix propensity.<sup>281</sup> Chao identified the " $\alpha 8$ " helix sequence as one such  $\alpha$ -helix forming sequence in PH20, and position 320 is within the  $\alpha 8$  helix sequence in PH20 (below).<sup>282</sup> Consequently, a skilled artisan

---

<sup>278</sup> EX1003, ¶¶ 231-232; EX1004, ¶¶ 41-42, 106, 116.

<sup>279</sup> EX1004, ¶¶ 43, 106, 116; EX1003, ¶¶ 228, 231.

<sup>280</sup> EX1003, ¶ 232; EX1004, ¶ 116.

<sup>281</sup> EX1050, 422-24, Table 2; EX1003, ¶ 230; EX1004, ¶¶ 69-70.

<sup>282</sup> EX1006, 6916, Figure 3; EX1003, ¶ 202; EX1004, ¶¶ 32, 108.

would have viewed lysine as a logical (and thus obvious) substitution for aspartic acid at position 320 in PH20<sub>1-447</sub>.<sup>283</sup>

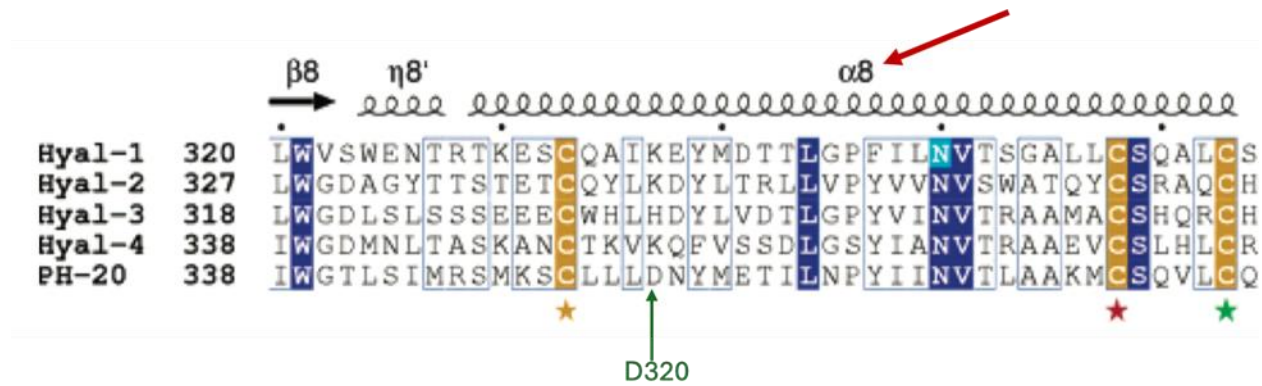

A skilled artisan also would have found the D320S substitution obvious.

While serine occurs less frequently than lysine in positions corresponding to 320 in PH20 in other hyaluronidases, it is found in other active, naturally occurring enzymes, suggesting it will be tolerated at position 320 in PH20.<sup>284</sup>

Consequently, a skilled person would have found lysine and serine to be obvious choices for a single amino acid substitution for aspartic acid at position 320 in PH20<sub>1-447</sub> pursuant to the guidance in the '429 Patent.<sup>285</sup>

<sup>283</sup> EX1003, ¶ 230; EX1004, ¶¶ 32, 108.

<sup>284</sup> EX1003, ¶ 230; EX1004, ¶¶ 32, 106.

<sup>285</sup> EX1003, ¶¶ 231-232.

**5. A Skilled Artisan Would Have Reasonably Expected the D320K and D320S Substitutions in PH20<sub>1-447</sub> to Yield Enzymatically Active PH20 Proteins**

*a) Patent Owner Cannot Contradict Its Past Representations to the PTO*

Replacing the aspartic acid at position 320 with lysine or serine (S) yields a PH20<sub>1-447</sub> with a single amino acid substitution in a non-essential region of the polypeptide.<sup>286</sup> In its '429 Patent, Patentee stated:

Those of skill in this art recognize that, in general, single amino acid substitutions in non-essential regions of a polypeptide do not substantially alter biological activity.<sup>287</sup>

Patentee also secured claims in the '429 patent to modified PH20<sub>1-447</sub> proteins with at least one substitution (*e.g.*, claim 1), despite not providing examples of PH20 proteins with any substitutions. Patentee, thus, made and relied on its statements that a skilled artisan would have expected **any** single amino acid substitution in **any** non-essential position of PH20<sub>1-447</sub> to not substantially affect the activity of the enzyme. Patentee should not be permitted to now contend a skilled artisan would not have reasonably expected that the D320K and

---

<sup>286</sup> See § VI.B.3; EX1003, ¶ 227; EX1004, ¶ 32.

<sup>287</sup> EX1005, 16:17-20.

D320S substitutions in PH20<sub>1-447</sub> would yield an enzyme with substantially the same activity as unmodified PH20<sub>1-447</sub>.

*b) Skilled Artisans Would Reasonably Expect D320K and D320S Substitutions to be Tolerated in PH20<sub>1-447</sub>*

Independently, a skilled artisan would have reasonably expected the D320K and D320S substitutions to not substantially alter the biological activity (hyaluronidase activity) of PH20<sub>1-447</sub>. Both experts noted that many naturally occurring homologous hyaluronidase proteins contain lysine or serine at positions corresponding to position 320 in PH20 (including lysine in three human hyaluronidases (Chao)), which suggests lysine and serine would be tolerated at that position in PH20.<sup>288</sup>

Dr. Park's sequence alignment also shows that many (8) different amino acids occur in homologous proteins at positions corresponding to position 320 in PH20.<sup>289</sup> The diversity of characteristics of those amino acids at that position (*e.g.*, large or small side chains, high or low helix propensities, net positive, negative, or zero charges, etc.) suggests that many different kinds of amino acids can be

---

<sup>288</sup> EX1003, ¶¶ 228-229, 231; EX1004, ¶¶ 106, 116.

<sup>289</sup> EX1004, ¶ 106.

tolerated at position 320 in PH20.<sup>290</sup> Consequently, a skilled artisan would expect both substitutions (D320K, D320S) to be tolerated in PH20.

The high frequency of occurrence of lysine at positions equivalent to 320 in naturally-occurring hyaluronidases, including in 3 of 4 human homologs of PH20 (Chao, Figure 3), along with lysine's high helix propensity, additionally would have led a skilled artisan to reasonably expect the D320K substitution would be tolerated in PH20<sub>1-447</sub>.<sup>291</sup>

*c) A PH20 Structural Model Confirms that PH20<sub>1-447</sub> Would Tolerate Lysine and Serine at Position 320*

Dr. Park assessed whether single amino acid substitutions in PH20<sub>1-447</sub> would be tolerated, including D320K and D320S, using a PH20 protein structural model generated by SWISS-MODEL using Chao's HYAL1 structure as the template, as would have been done in 2011 by a skilled artisan.<sup>292</sup>

---

<sup>290</sup> EX1003, ¶ 229; EX1004, ¶ 106.

<sup>291</sup> EX1003, ¶¶ 231-232; EX1004, ¶¶ 116, 70.

<sup>292</sup> EX1004, ¶¶ 39-40, 149-150; EX1003, ¶¶ 234-238; EX1006, 6915, Figure 2; EX1017, 229; EX1012, 1-2, 4; EX1014, 348, 370; EX1038, 3382.

Dr. Park explains that his PH20 model was reliable in the region of position 320 of PH20 based on QMEAN values,<sup>293</sup> and would be very similar to a PH20 model generated by SWISS-MODEL in 2011 (*e.g.*, it used 165 conserved positions in the backbone of the two proteins).<sup>294</sup>

Dr. Park also devised a consistent, objective methodology for assessing substitutions using the PH20<sub>1-447</sub> model.<sup>295</sup> Factors he considered included, *inter alia*, the number of neighboring residues at position 320 (*i.e.*, those within 5 Å), the various possible interactions between neighbors (*e.g.*, hydrophobic, charged, van der Waals, steric, etc.), and solvent accessibility.<sup>296</sup> Where interactions were observed, Dr. Park assessed the impact of them (*e.g.*, hydrophobic-hydrophilic,

---

<sup>293</sup> EX1004, ¶¶ 151-153 (satisfactory local and global QMEAN values); EX1037, 346-47; EX1069, 3; EX1012, 4, 8.

<sup>294</sup> EX1004, ¶¶ 154-155, 159; EX1038, 3382-4; EX1017, 229-230; EX1012, 1-2; EX1014, 348, 370; EX1066, 5-11.

<sup>295</sup> EX1004, ¶¶ 102-103; *see generally id.* at § IV.C (description of Dr. Park's methodology); EX1003, ¶¶ 225-226.

<sup>296</sup> EX1004, ¶¶ 44-47, 53-60, 65-85, Appendix D-5; EX1035, 1408, Table 2; EX1043, 2, Table 1.

effects on secondary structures, size related issues such as steric clashes or creation/filling of “holes” in the structure).<sup>297</sup>

Dr. Park assessed the environment of position 320 visually by comparing the wild-type with the version incorporating substituted amino acids at position 320 using functionality within the viewer (PyMol) and as a modeled sequence generated from the PH20<sub>1-447</sub> sequence incorporating the single substitution in SWISS-MODEL.<sup>298</sup> These technologies were available in 2011.<sup>299</sup> He used his methodology to assess substitutions representing diverse interactions, and confirmed it provided a consistent, objective and unbiased evaluation of substitutions.<sup>300</sup>

Dr. Park assigned a score for each substitution reflecting the aggregate effect of the interactions he observed (below).<sup>301</sup>

---

<sup>297</sup> EX1004, ¶¶ 62-63, 85.

<sup>298</sup> EX1004, ¶¶ 61, 107, 115, 118, 122, 138, 140, 164-166; EX1003, ¶¶ 235, 237.

<sup>299</sup> EX1004, ¶¶ 149, 154-155, 163, 165-167; EX1066, 1, 4, 7, 17, 25, 27, 35, 39, 41; EX1067, 1, 6-7, 53-57, 61-62; EX1012, 1-4; EX1003, ¶¶ 20-22.

<sup>300</sup> EX1004, ¶¶ 102-103; EX1003, ¶¶ 225-226.

<sup>301</sup> EX1004, ¶¶ 85-87.

<i>Score</i>	<i>Expected Impact</i>	<i>Expected Toleration</i>
1	Significantly Destabilized	Likely Not Tolerated
2	Neutral or Minor Impacts	Tolerated
3	Improved Stability	Tolerated

Dr. Park assigned a score of 3 for the D320K substitution in PH20<sub>1-447</sub>, indicating it would be expected to confer improved stability.<sup>302</sup> He observed that in the wild-type environment, there is a deep hydrophobic pocket around position 320 that limits solvent accessibility to the side chains, but that it is exposed to solvent at the top.<sup>303</sup> He also observed that there is a negative surface charge at position 320 that creates electrostatic repulsion with the charged carboxyl group of D320.<sup>304</sup> When the lysine was substituted in position 320, Dr. Park observed that: (i) it introduces a stabilizing salt-bridge with E324 (left image), and a hydrogen bond to the main carbonyl group of P32, (ii) the long aliphatic chain of lysine participates in hydrophobic interactions with P32 and L317 residues (right image), and (iii) its positive charge offsets nearby negative charges.<sup>305</sup> Overall, Dr. Park found that the D320K substitution would be stabilizing, meaning that D320K

---

<sup>302</sup> EX1004, ¶ 123, Appendix C.

<sup>303</sup> EX1004, ¶ 110.

<sup>304</sup> EX1004, ¶¶ 112-114.

<sup>305</sup> EX1004, ¶¶ 119-121, 123.

PH20<sub>1-447</sub> would be expected to retain the hyaluronidase activity of the unmodified PH20<sub>1-447</sub>.<sup>306</sup>

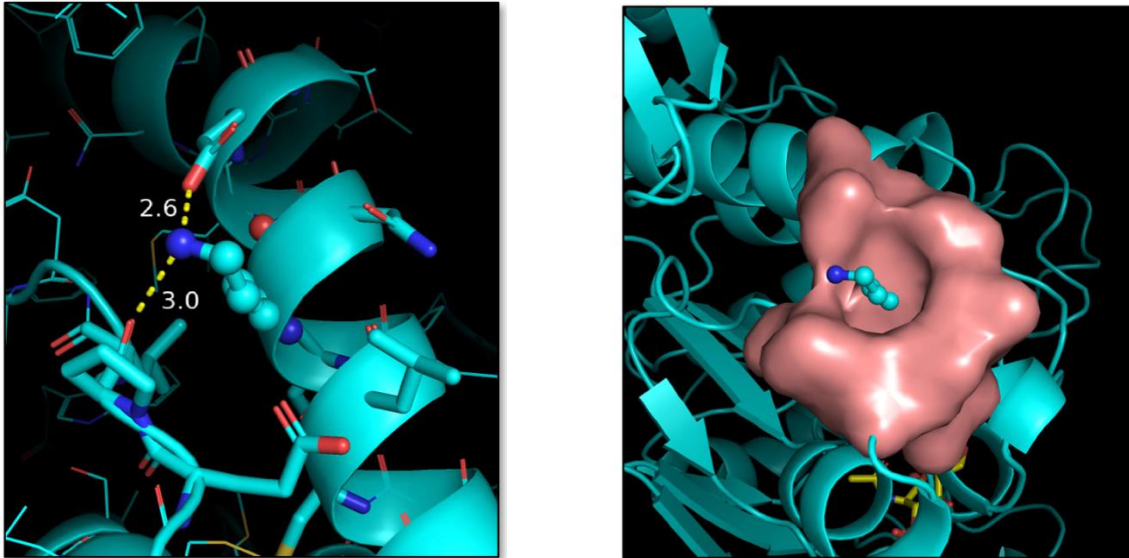

Dr. Park's analysis of the D320S PH20 model shows this substitution would likely be tolerated. He explained that while the D320S PH20 mutant would lose some stabilizing interactions provided by D at position 320, serine is charge neutral and would remove some of the destabilizing charged interactions present in the wild-type structure (below).<sup>307</sup> He thus gave the serine substitution a rating of 2.<sup>308</sup>

---

<sup>306</sup> EX1004, ¶ 123.

<sup>307</sup> EX1004, ¶ 139.

<sup>308</sup> EX1004, ¶ 141.

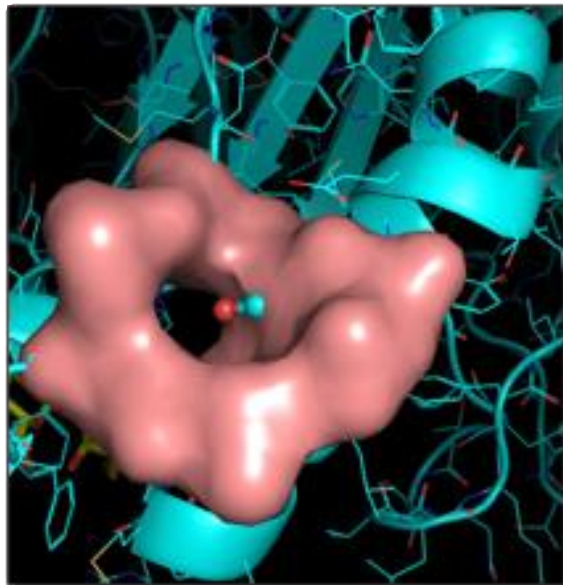

Dr. Park's visualization-based assessment was a prevalent technique used in 2011.<sup>309</sup> Similarly, his technique of assessing interactions between neighbors and assigning an overall score reflecting the aggregate effects of those interactions is consistent with methods reported in peer review publications.<sup>310</sup>

---

<sup>309</sup> EX1017, 228 (“... a structural biologist’s intuition is often an important tool in the design of the desired variants, an approach that may be termed structure-based protein design to borrow a term from the drug design field. Visualization of the known reference structure is a key component of this.”); EX1004, ¶¶ 22, 33-36; EX1003, ¶¶ 236-238.

<sup>310</sup> EX1004, ¶¶ 48-52; EX1031, 459, 462-64, 469-71, Table 3; EX1032, 265-66; EX1003, ¶ 238.

Dr. Hecht reviewed Dr. Park's analysis and conclusions concerning the D320K and D320S single substitutions and agreed with them.<sup>311</sup> Dr. Hecht concluded that lysine would likely have been tolerated at position 320 as a single substitution in PH20<sub>1-447</sub> because lysine would have a stabilizing effect due to (i) its compatibility with the solvent-exposed pocket at position 320, and (ii) formation of a salt bridge with E324.<sup>312</sup> He observed that serine should be tolerated because position 320 tolerates many different kinds of residues, and the serine substitution would remove destabilizing interactions in the wild-type protein.<sup>313</sup>

The common disclosure defines an "active mutant" as a modified PH20 polypeptide with at least ~40% of the activity of unmodified PH20<sub>1-447</sub>.<sup>314</sup> Drs. Hecht and Park each independently concluded that the D320K and D320S substitutions would have been tolerated by PH20<sub>1-447</sub>.<sup>315</sup> A skilled artisan thus

---

<sup>311</sup> EX1003, ¶¶ 237, 240.

<sup>312</sup> EX1003, ¶ 241.

<sup>313</sup> EX1003, ¶ 242.

<sup>314</sup> EX1001, 75:47-52; *also id.* at 79:29-33.

<sup>315</sup> EX1003, ¶¶ 240-242, 244; EX1004, ¶¶ 17, 123, 141.

would have reasonably expected that the D320K and D320S PH20<sub>1-447</sub> polypeptides would exhibit at least 40% of the activity of unmodified PH20<sub>1-447</sub>.<sup>316</sup>

Based on the '429 Patent, Chao, and information available in 2011, the D320K and D320S PH20<sub>1-447</sub> mutant polypeptides would have been obvious to a skilled artisan in 2011. And because claims 1-2, 6-15, and 24-25 each encompass one of these single-substitution mutants, each claim is unpatentable.

### **C. Dependent Claims 5, 16-23, and 26-40 Are Obvious**

Each of claims 5, 16-23, and 26-40 defines subject matter that would have been obvious to a skilled artisan.

#### **1. Claims 5, 35**

Claims 5 and 35 requires the modified PH20 polypeptide of claim 1 to be “soluble.”

The '429 Patent indicates that PH20<sub>1-447</sub> is a soluble form of the PH20 protein because it truncates the C-terminal residues above position 448 (483) containing the GPI anchor sequence (i.e., it is C-terminally truncated).<sup>317</sup> A skilled artisan would have expected that changing aspartic acid (D) to lysine (K) or serine

---

<sup>316</sup> EX1003, ¶ 244.

<sup>317</sup> EX1005, 3:57-62; 87:52-88:24.

(S) at position 320 would not affect the solubility of PH20<sub>1-447</sub> as it would not meaningfully alter the overall structure of the protein.<sup>318</sup>

## 2. Claims 16-18

Claims 16-18 require the modified PH20 polypeptide to “comprise[] one or more post-translational modifications” including glycosylation (claims 16-17) and be a “glycoprotein that comprises an N-acetylglucosamine moiety linked to each of at least three asparagine (N) residues” (18).

The '429 Patent teaches (i) that human PH20 must be glycosylated to exhibit activity, and (ii) expression of PH20<sub>1-447</sub> in mammalian (CHO) host cells that yield active forms of PH20<sub>1-447</sub>.<sup>319</sup> It further teaches that “N- and O-linked glycans are attached to polypeptides through asparagine-N-acetyl-D-glucosamine ... linkages,” and claims PH20 polypeptides (including PH20<sub>1-447</sub>) having asparagine-linked sugar moieties.<sup>320</sup> Frost reports that the recombinant production of PH20<sub>1-447</sub> in CHO cells “resulted in a 447 amino acid 61 kDA glycoprotein with a properly processed amino terminus and 6 N-linked glycosylation sites.”<sup>321</sup>

---

<sup>318</sup> EX1003, ¶¶ 206, 213, 233.

<sup>319</sup> EX1005, 95:13-30, 40:41-51, 89:53-91:67, 88:5-9.

<sup>320</sup> EX1005, 3:27-35, claims 1, 6.

<sup>321</sup> EX1013, 432.

Based on the '429 Patent and knowledge in the art, a skilled artisan would have found it obvious to produce D320K and D320S PH20<sub>1-447</sub> in a CHO cell, and that doing so causes six N-linked glycosylation sites to be glycosylated.<sup>322</sup>

### 3. Claims 19-22, 33-34

Claims 19-20 and 33-34 concern conjugation of a modified PH20 polypeptide to (i) a polymer (claim 19) that may be polyethylene glycol (claim 20), (ii) a moiety such as a toxin, drug, label, or multimerization domain (claim 33), or (iii) an Fc (sic) domain (claim 34). Claim 21 specifies the modified PH20 polypeptide further comprises a heterologous signal sequence, while claim 22 specifies a chimeric peptide comprising modified PH20 polypeptides of claim 1.

A skilled artisan would have found these further modifications to the D320K and D320S PH20<sub>1-447</sub> mutants obvious from the '429 Patent.<sup>323</sup> The '429 Patent teaches PH20<sub>1-447</sub> proteins with mutations (“sHASEPGs”) can be (i) “modif[ied]” “with polymers such as polyethylene glycol”;<sup>324</sup> (ii) conjugated to “one or more targeting agents” (*e.g.*, any moiety that specifically binds to a receptor);<sup>325</sup> (iii)

---

<sup>322</sup> EX1003, ¶¶ 207-208, 213-214.

<sup>323</sup> EX1003, ¶¶ 213, 215.

<sup>324</sup> EX1005, 3:64-4:1, 4:45-53, 26:20-28:4.

<sup>325</sup> EX1005, 18:33-52.

attached to a label;<sup>326</sup> and (iv) incorporated into fusion (*i.e.*, “chimeric”) proteins.<sup>327</sup> It also teaches expression of modified PH20 polypeptides that incorporate a heterologous signal sequence.<sup>328</sup>

#### 4. Claims 23, 26-32, 36-40

Claim 23 specifies a pharmaceutical composition comprising any modified PH20 polypeptide in the genus of claim 1. Claims 26-29 add a “therapeutically active agent formulated in the same composition or in a separate composition” (26), and that the active agent may be a “drug” (27) or “chemotherapeutic agent” (28), or “antibody” (29).

Claims 30-32 concern methods of treating “hyaluronan-associated disease” (30) such as cancer (31) or a “solid tumor” (32) by administering any of the modified PH20 polypeptides captured by claim 1.

Claims 36-40 concern methods for increasing delivery of a “therapeutic agent” by administration of a “modified PH20 polypeptide of claim 1” (36) via

---

<sup>326</sup> EX1005, 38:40-49, 40:15-21.

<sup>327</sup> EX1005, 18:33-52, 47:10-22, 51:25-30.

<sup>328</sup> EX1005, 34:33-37; 88:28-90:15 (“Kappa leader sequence” used in expression of PH20 polypeptides).

subcutaneous injection (37), either before the therapeutic agent (38) or in the “same composition” (40), and wherein the therapeutic agent is an antibody (39).

The '429 Patent provides extensive guidance concerning and claims pharmaceutical compositions comprising soluble, neutral PH20 polypeptides (*e.g.*, PH20<sub>1-447</sub>), alone or with other therapeutic agents including antibodies and agents used in treating cancer and hyaluronan-associated disease.<sup>329</sup> It similarly describes and claims methods of administering them subcutaneously using formulations that combine an enzymatically active “sHASEPGs” (*e.g.*, PH20<sub>1-447</sub> with one substitution) with another therapeutic agent, which together enable increasing delivery of the therapeutic agent after injection.<sup>330</sup> It likewise explains that the therapeutic agent and the PH20 can be subcutaneously administered together or sequentially.<sup>331</sup>

---

<sup>329</sup> EX1005, 8:60-9:4, 54:40-55:35, 56:28-57:21, 55:61-56:9, 56:66-57:21, 63:41-44, 73:4-74:29, claims 14, 29, 33; EX1003, ¶¶ 209-211.

<sup>330</sup> EX1005, 8:25-38, 54:40-65, 56:28-56, 57:22-36, 58:59-59:12, 63:40-64:4, 73:4-20, 76:18-77:37, claim 27; EX1003, ¶ 212.

<sup>331</sup> EX1005, 8:25-37, 8:60-9:4, 75:25-50, 76:19-77:33, 99:27-100:47; EX1003, ¶¶ 210-211.

Because the D320K and D320S PH20<sub>1-447</sub> polypeptides would be expected to have a comparable structure and activity as unmodified PH20<sub>1-447</sub>, a skilled artisan would have believed each would be equivalently useful as the unmodified PH20<sub>1-447</sub> in pharmaceutical compositions, methods of administration, and methods of treatment described in the '429 Patent.<sup>332</sup> Indeed, in the '429 Patent, Patentee secured claims encompassing pharmaceutical compositions containing PH20 polypeptides with 1+ substitutions and chemotherapeutic agents despite the absence of any exemplification.<sup>333</sup> Claims 23 and 26-32 also impose no restrictions on the makeup of the pharmaceutical composition.

The '429 Patent also teaches that hyaluronidases, including PH20<sub>1-447</sub>, can be used to enhance delivery of another therapeutic agent, and illustrates administering them with antibodies.<sup>334</sup> A PH20<sub>1-447</sub> polypeptide with only a D320K or D320S substitution would be expected to cause spreading comparably to unmodified PH20<sub>1-447</sub> as claims 36-40 specify.<sup>335</sup> A skilled artisan would have expected a

---

<sup>332</sup> EX1003, ¶¶ 209-212, 233.

<sup>333</sup> EX1005, claims 29, 30, 50.

<sup>334</sup> EX1005, 8:25-37, 54:40-45, 56:36-57:21, 73:4-19, 97:36-98:18, 98:49-99:24, 100:7-47; EX1003, ¶¶ 210-211.

<sup>335</sup> EX1003, ¶¶ 212, 233.

PH20<sub>1-447</sub> with one substitution (D320K or D320S) to retain much of its hyaluronidase activity, and the claims impose no minimum degree of “increased delivery.”<sup>336</sup> A skilled artisan also would have expected the Hyal-EGF domain in these mutants to be the same as in unmodified PH20<sub>1-447</sub> as the substitutions are not within that domain sequence.<sup>337</sup>

A skilled artisan thus would have found the claimed compositions and methods of increasing delivery to have been obvious from the '429 Patent.<sup>338</sup>

**D. There Is No Nexus Between the Claims and Any Evidence of Putative Secondary Indicia**

Well-established law holds that evidence of secondary indicia cannot support non-obviousness if it does not have nexus to the claims. A key question in a nexus analysis is whether such evidence is commensurate with the scope of the claims. The answer here is a definitive no.

Patentee is likely to dispute that the D320K or D320S PH20<sub>1-447</sub> substitutions are obvious. For example, Patentee may contend that either variant has unexpectedly high hyaluronidase activity as a single substitution mutant. Demonstrating that result for one mutant out of the  $\sim 10^{59}$  and  $10^{112}$  modified PH20

---

<sup>336</sup> EX1003, ¶¶ 212, 217, 232-233.

<sup>337</sup> EX1003, ¶ 233.

<sup>338</sup> EX1003, ¶¶ 209-212, 217, 233.

polypeptides encompassed by the claims utterly fails to establish a nexus between that evidence and the claims. As explained in § V.A.1, the single-substitution D320K and D320S PH20<sub>1-447</sub> mutants are not representative of the numerous, structurally different proteins encompassed by the claims, particularly those expected to be inactive. No evidence or explanation is provided in the common disclosure that resolves this confusion.

If Patentee advances evidence or arguments concerning nexus, consideration of that issue should be deferred until after institution, and Petitioner reserves its right to contest such evidence.

**VII. The Board Should Not Exercise Its Discretion Under § 324(a) or § 325(d)**

No litigation involving the '652 Patent is pending, making discretionary denial unwarranted under the factors in *Apple Inc. v. Fintiv, Inc.*, IPR2020-00019, Paper 11, 5-6 (P.T.A.B. Mar. 20, 2020).

The examination record also does not warrant the Board exercising its discretion to not institute. As explained in § IV.C, no obviousness rejections were raised during prosecution.<sup>339</sup> The present obviousness grounds also rely on Chao (EX1006), which was not cited or considered during examination, and are

---

<sup>339</sup> EX1002, 1237-46.

supported by evidence not available to the Examiner (*e.g.*, expert testimony of Drs. Hecht and Park).

Also, while certain indefiniteness rejections were imposed and overcome by claim amendments,<sup>340</sup> the Examiner erred by not rejecting the claims for lack of written description and non-enablement. *See* §§ V.A and V.B.

There is no proper basis for the Board to exercise its discretion to not institute trial.

## VIII. CONCLUSION

For the foregoing reasons, the challenged claims are unpatentable.

Dated: March 7, 2025

Respectfully Submitted,

/Jeffrey P. Kushan/

Jeffrey P. Kushan  
Reg. No. 43,401  
Sidley Austin LLP  
1501 K Street, N.W.  
Washington, D.C. 20005  
jkushan@sidley.com  
(202) 736-8914  
Attorney for Petitioner

---

<sup>340</sup> EX1002, 1264-65, 1280-81.

**EXHIBIT LIST**

No.	Exhibit Description
1001	U.S. Patent No. 12,049,652
1002	File History of U.S. Patent No. 12,049,652
1003	Declaration of Dr. Michael Hecht
1004	Declaration of Dr. Sheldon Park
1005	U.S. Patent No. 7,767,429
1006	Chao et al., "Structure of Human Hyaluronidase-1, a Hyaluronan Hydrolyzing Enzyme Involved in Tumor Growth and Angiogenesis," <i>Biochemistry</i> , 46:6911-6920 (2007)
1007	WO 2010/077297, published 8 July 2010
1008	Stern et al., "The Hyaluronidases: Their Genomics, Structures, and Mechanisms of Action," <i>Chem. Rev.</i> 106:818-839 (2006)
1009	Jedzrejas et al., "Structures of Vertebrate Hyaluronidases and Their Unique Enzymatic Mechanism of Hydrolysis," <i>Proteins: Structure, Function and Bioinformatics</i> , 61:227-238 (2005)
1010	Zhang et al., "Hyaluronidase Activity of Human Hyal1 Requires Active Site Acidic and Tyrosine Residues," <i>J. Biol. Chem.</i> , 284(14):9433-9442 (2009)
1011	Arming et al., "In vitro mutagenesis of PH-20 hyaluronidase from human sperm," <i>Eur. J. Biochem.</i> , 247:810-814 (1997)
1012	Bordoli et al., "Protein structure homology modeling using SWISS-MODEL workspace," <i>Nature Protocols</i> , 4(1):1-13 (2008)
1013	Frost, "Recombinant human hyaluronidase (rHuPH20): an enabling platform for subcutaneous drug and fluid administration," <i>Expert Opinion on Drug Delivery</i> , 4(4):427-440 (2007)
1014	Branden & Tooze, "Introduction to Protein Structure," Second Ed., Chapters 1-6, 11-12, 17-18 (1999)
1015	Table Associating Citations from the '652 Patent (EX1001) to Corresponding Citations in the '731 Application (EX1026)

No.	Exhibit Description
1016	Steipe, "Consensus-Based Engineering of Protein Stability: From Intrabodies to Thermostable Enzymes," <i>Methods in Enzymology</i> , 388:176-186 (2004)
1017	Green, "Computer Graphics, Homology Modeling, and Bioinformatics," <i>Protein Eng'g &amp; Design</i> , Ch. 10, 223-237 (2010)
1018	Chica et al., "Semi-rational approaches to engineering enzyme activity: combining the benefits of directed evolution and rational design," <i>Curr. Opin. Biotechnol.</i> , (4):378-384 (2005)
1019	Hardy et al., "Assessment of contraceptive vaccines based on recombinant mouse sperm protein PH20," <i>Reprod.</i> , 127:325-334 (2004)
1020	Pomering et al., "Restricted Entry of IgG into Male and Female Rabbit Reproductive Ducts Following Immunization with Recombinant Rabbit PH-20," <i>Am. J. Reprod. Immunol.</i> , (3):174-82 (2002)
1021	Baba et al., "Mouse Sperm Lacking Cell Surface Hyaluronidase PH-20 Can Pass through the Layer of Cumulus Cells and Fertilize the Egg," <i>J. Biol. Chem.</i> , 277(33):30310-4 (2002)
1022	Primakoff et al., "Reversible Contraceptive Effect of PH-20 Immunization in Male Guinea Pigs," <i>Biol Reprod.</i> , 56(5):1142-6 (1997)
1023	Tung et al., "Mechanism of Infertility in Male Guinea Pigs Immunized with Sperm PH-20," <i>Biol. Reprod.</i> , 56(5):1133-41 (1997)
1024	Rosengren et al., "Recombinant Human PH20: Baseline Analysis of the Reactive Antibody Prevalence in the General Population Using Healthy Subjects," <i>BioDrugs</i> , 32(1):83-89 (2018)
1025	U.S. Patent No. 9,447,401
1026	U.S. Patent Application No. 13/694,731
1027	[Reserved]
1028	[Reserved]
1029	Gmachl et al., "The human sperm protein PH-20 has hyaluronidase activity," <i>FEBS Letters</i> , 3:545-548 (1993)

No.	Exhibit Description
1030	Sills, "Retraction," <i>Science</i> , 319:569 (2008)
1031	Yue et al., "Loss of Protein Structure Stability as a Major Causative Factor in Monogenic Disease," <i>J. Mol. Biol.</i> , 353:459-473 (2005)
1032	Wang & Moulton, "SNPs, Protein Structure, and Disease," <i>Hum. Mutation</i> , 17:263-270 (2001)
1033	Marković-Housley et al., "Crystal Structure of Hyaluronidase, a Major Allergen of Bee Venom," <i>Structure</i> , 8:1025-1035 (2000)
1034	"Negative Results," <i>Nature: Editorials</i> , 453:258 (2008)
1035	Lins et al., "Analysis of Accessible Surface of Residues in Proteins," <i>Protein Sci.</i> , 12:1406-1417 (2003)
1036	Hayden, "Chemistry: Designer Debacle," <i>Nature</i> , 453:275-278 (2008)
1037	Benkert et al., "Toward the Estimation of the Absolute Quality of Individual Protein Structure Models," <i>Bioinformatics</i> , 27:343-350 (2010)
1038	Schwede et al., "SWISS-MODEL: An Automated Protein Homology-Modeling Server," <i>Nucleic Acids Res.</i> , 31:3381-3385 (2003)
1039	Alberts, "Molecular Biology of the Cell," Fifth Edition, Chapter 3 (2007).
1040	He et al., "NMR Structures of Two Designed Proteins with High Sequence Identity but Different Fold and Function," <i>PNAS</i> , 105:14412-14417 (2008)
1041	Alexander et al., "A Minimal Sequence Code for Switching Protein Structure and Function," <i>PNAS</i> , 106:21149-21154 (2009)
1042	Ruan et al., "Design and Characterization of a Protein Fold Switching Network," <i>Nature Comm.</i> , 14 (2023)
1043	Sievers et al., "Fast, Scalable Generation of High-Quality Protein Multiple Sequence Alignments Using Clustal Omega," <i>Molecular Sys. Biology</i> , 7.1 (2011)
1044	Mihel, "PSAIA – Protein Structure and Interaction Analyzer," <i>BMC Structural Biology</i> , 8:21 (2008)

No.	Exhibit Description
1045	Redline Comparison of the '731 and '652 Specifications
1046	Beasley & Hecht, "Protein Design: The Choice of <i>de Novo</i> Sequences," J. Biological Chemistry, 272:2031-2034 (1997)
1047	Xiong et al., "Periodicity of Polar and Nonpolar Amino Acids is the Major Determinant of Secondary Structure in Self-Assembling Oligomeric Peptides," PNAS, 92: 6349-6353 (1995)
1048	Hayden, "Key Protein-Design Papers Challenged," Nature, 461:859 (2009)
1049	KEGG, DRUG: Hyaluronidase (human recombinant), available at: <a href="https://www.genome.jp/entry/D06604">https://www.genome.jp/entry/D06604</a>
1050	Pace & Scholtz, "A Helix Propensity Scale Based on Experimental Studies of Peptides and Proteins," Biophysical J. 75:422-427 (1998)
1051	U.S. Patent Application No. 61/631,313
1052	U.S. Patent Application No. 61/796,208
1053	Hom_pre2011
1054	Hom_pre2011_header
1055	Hom_pre2011_header_clean
1056	Hom_pre2011.fasta
1057	Ph20_pre2011.aln-clustal_num
1058	Ph20_pre2011 Alignment html
1059	Leisola & Turunen, "Protein Engineering: Opportunities and Challenges," Appl. Microbiol. Biotechnol. 75:1225-1232 (2007)
1060	Hecht et al., "De Novo Proteins from Designed Combinatorial Libraries," Protein Sci., 13:1711-1723 (2004)
1061	Rosengren et al., "Clinical Immunogenicity of rHuPH20, a Hyaluronidase Enabling Subcutaneous Drug Administration," AAPS J., 17:1144-1156 (2015)
1062	[Reserved]
1063	[Reserved]

No.	Exhibit Description
1064	Collection of BLAST Webpages from the Internet Archive, navigable from: <a href="https://web.archive.org/web/20111022151531/http://www.clustal.org/omega/">https://web.archive.org/web/20111022151531/http://www.clustal.org/omega/</a>
1065	Collection of Clustal Omega Webpages from the Internet Archive, navigable from: <a href="https://web.archive.org/web/20111022151531/http://www.clustal.org/omega/">https://web.archive.org/web/20111022151531/http://www.clustal.org/omega/</a>
1066	Collection of SWISS-MODEL Webpages from the Internet Archive, navigable from: <a href="https://web.archive.org/web/20110519141121/http://swissmodel.expasy.org/?pid=smh01&amp;uid=&amp;token=">https://web.archive.org/web/20110519141121/http://swissmodel.expasy.org/?pid=smh01&amp;uid=&amp;token=</a>
1067	Collection of PyMol Webpages from the Internet Archive, navigable from: <a href="https://web.archive.org/web/20110701072314/http://pymol.org/">https://web.archive.org/web/20110701072314/http://pymol.org/</a>
1068	Declaration of Jeffrey P. Kushan
1069	Swiss Model Printout of PH20 Model
1070	Swiss Model Printout of PH20 Model with D320K Mutation
1071	Swiss Model Printout of PH20 Model with D320H Mutation
1072	Swiss Model Printout of PH20 Model with D320R Mutation
1073	Swiss Model Printout of PH20 Model with D320S Mutation
1074	[Reserved]
1075	[Reserved]
1076	[Reserved]
1077	[Reserved]
1078	[Reserved]
1079	Hunnicuttt et al., "Sperm Surface Protein PH-20 Is Bifunctional: One Activity Is a Hyaluronidase and a Second, Distinct Activity Is Required in Secondary Sperm-Zona Binding," Biol. Reprod., 55(1):80-86 (1996)

**CERTIFICATE OF COMPLIANCE**

I hereby certify that this brief complies with the type-volume limitations of 37 C.F.R. § 42.24, because it contains 18,655 words (as determined by the Microsoft Word word-processing system used to prepare the brief), excluding the parts of the brief exempted by 37 C.F.R. § 42.24.

Dated: March 7, 2025

Respectfully Submitted,

/Jeffrey P. Kushan/

Jeffrey P. Kushan  
Reg. No. 43,401  
Sidley Austin LLP  
1501 K Street, N.W.  
Washington, D.C. 20005  
jkushan@sidley.com  
(202) 736-8914  
Attorney for Petitioner

**CERTIFICATE OF SERVICE**

Pursuant to 37 C.F.R. § 42.6(e), I hereby certify that on this 7th day of March, 2025, I caused to be served a true and correct copy of the foregoing and any accompanying exhibits by FedEx on the following counsel:

<p>Morgan, Lewis &amp; Bockius LLP                  2222 Market Street                  Philadelphia, PA 19103                  United States</p>	<p>Mark Snyder                  Senior Vice President, General Counsel, CCO &amp; Secretary                  Halozyme Therapeutics                  12390 El Camino Real                  San Diego, CA 92130                  United States</p>
<p>Robert Smyth                  Morgan, Lewis &amp; Blockius LLP                  1111 Pennsylvania Avenue, NW                  Washington, DC 20004-2541                  United States</p>	<p>Eldora Ellison                  Sterne, Kessler, Goldstein &amp; Fox PLLC                  1101 K Street NW, 10th Floor                  Washington, DC 20005                  United States</p>

Dated: March 7, 2025

Respectfully Submitted,

/Jeffrey P. Kushan/

Jeffrey P. Kushan  
 Reg. No. 43,401  
 Sidley Austin LLP  
 1501 K Street, N.W.  
 Washington, D.C. 20005  
 jkushan@sidley.com  
 (202) 736-8914  
 Attorney for Petitioner